

# INSTRUCTION MANUAL

## Multi-Range DC Power Supply PSW-A Series

PSW-360L30A  
PSW-360L80A  
PSW-360M160A  
PSW-360M250A  
PSW-360H800A

PSW-720L30A  
PSW-720L80A  
PSW-720M160A  
PSW-720M250A  
PSW-720H800A

PSW-1080L30A  
PSW-1080L80A  
PSW-1080M160A  
PSW-1080M250A  
PSW-1080H800A



# CONTENTS

USING THE PRODUCT SAFELY .....	I -IV
1. GETTING STARTED .....	5
1.1. PSW-A Series Overview .....	5
1.1.1. Series lineup (Total 15 models) .....	5
1.1.2. Main Features .....	6
1.1.3. Accessories .....	7
1.2. Appearance .....	9
1.2.1. Front Panel .....	9
1.2.2. Rear Panel .....	12
1.3. Theory of Operation .....	16
1.3.1. Operating Area Description .....	16
1.3.2. CC and CV Mode .....	19
1.3.3. Slew Rate .....	20
1.3.4. Bleeder Control .....	20
1.3.5. Internal Resistance .....	23
1.3.6. Protection function .....	24
1.3.7. Considerations .....	24
1.3.8. Output grounding .....	26
2. OPERATION .....	28
2.1. Set Up .....	28
2.1.1. Line Voltage Connection: 1080W Models .....	28
2.1.2. Filter Installation .....	29
2.1.3. Power Up .....	30
2.1.4. Regarding load line selection .....	30
2.1.5. Output Terminals: Low voltage model .....	31
2.1.6. Attaching output terminal cover: Low voltage model .....	32
2.1.7. Output Terminals: High voltage model .....	33
2.1.8. Attaching output terminal cover: High voltage model .....	36
2.1.9. Using the Rack Mount Kit .....	36
2.1.10. Using the Voltage and Current knob .....	37
2.1.11. Reset to Factory Default Settings .....	38
2.1.12. Verifying firmware version and system information .....	38
2.2. Basic Operation .....	41
2.2.1. Setting OVP/OCP Levels .....	41
2.2.2. Set to CV Mode .....	43

2.2.3.	Set to CC Mode .....	45
2.2.4.	Set to CP Mode .....	47
2.2.5.	Display Modes .....	48
2.2.6.	Panel Lock.....	48
2.2.7.	Remote Sense.....	49
2.3.	One-control parallel operation .....	51
2.3.1.	Overview of one-control parallel operation .....	51
2.3.2.	Wiring for one-control parallel operation.....	53
2.3.3.	Settings and checking for one-control parallel operation.....	55
2.4.	One-control series operation .....	56
2.4.1.	Overview of one-control series operation .....	56
2.4.2.	Wiring for one-control series operation.....	58
2.4.3.	Settings and checking for one-control series operation.....	59
3.	Function settings .....	61
3.1.	Function settings list .....	61
3.1.1.	Normal Function .....	61
3.1.2.	USB & GP-IB .....	62
3.1.3.	LAN.....	62
3.1.4.	UART (RS-232C).....	63
3.1.5.	Cooling fan stop function .....	63
3.1.6.	Logging function .....	63
3.1.7.	Set value digit fixed function .....	63
3.1.8.	tUVP function.....	64
3.1.9.	System setting.....	64
3.1.10.	Power On Configuration.....	64
3.1.11.	Calibration .....	65
3.2.	Normal Function Settings .....	66
3.2.1.	Output ON/OFF Delay Time .....	66
3.2.2.	V-I mode slew rate setting .....	66
3.2.3.	Internal resistance setting.....	68
3.2.4.	Bleeder circuit control .....	69
3.2.5.	Buzzer ON/OFF control .....	69
3.2.6.	Measurement Average Setting .....	69
3.2.7.	Output key operation settings .....	69
3.3.	USB/GPIB/UART/LAN Settings .....	70
3.3.1.	USB setting.....	70
3.3.2.	GP-IB Address setting .....	70
3.3.3.	UART communication setting .....	70
3.3.4.	LAN Settings.....	71
3.4.	System Settings.....	73

3.4.1.	Factory Set Value .....	73
3.4.2.	Show Version .....	73
3.5.	Function settings at power-on .....	74
3.5.1.	Voltage setting Control .....	74
3.5.2.	Current setting Control .....	74
3.5.3.	Power-ON Output .....	75
3.5.4.	External Out Logic .....	75
3.5.5.	Power Switch trip .....	75
3.6.	Calibration .....	75
3.7.	Setting Normal Function Settings .....	75
3.8.	Setting Power on Configuration Settings .....	76
4.	Special functions .....	78
4.1.	Cooling fan stop function .....	78
4.1.1.	Fan stop time setting .....	78
4.1.2.	Executing the fan stop function .....	79
4.2.	Logging function .....	80
4.2.1.	Logging time interval settings .....	80
4.2.2.	Logging function operation: USB memory .....	81
4.2.3.	CSV file output to USB memory .....	84
4.2.4.	Logging function operation: digital communication .....	86
4.2.5.	Logging data output to controller .....	88
4.3.	Set value digit fixed function .....	91
4.3.1.	Setting method of setting digit .....	91
4.4.	tUVP function .....	92
4.4.1.	Setting method of the tUVP function .....	92
4.4.2.	Output on/off operation when UVP function is enabled .....	94
4.5.	Test mode function .....	95
4.5.1.	Test mode File Format .....	95
4.5.2.	Test mode setting items .....	95
4.5.3.	Setting the Test mode Settings .....	96
4.5.4.	Load test mode from USB memory .....	97
4.5.5.	Run Test mode .....	98
4.5.6.	Export Test mode to USB .....	100
4.5.7.	Remove test mode data .....	101
4.5.8.	Checking the Available Memory .....	101
4.5.9.	The test mode data file .....	101
5.	ANALOG CONTROL .....	106
5.1.	Analog Control Connector Overview .....	106
5.1.1.	External Voltage Control of Voltage Output .....	109
5.1.2.	External Voltage Control of Current Output .....	110



5.1.3.	External Resistance Control of Voltage Output .....	112
5.1.4.	External Resistance Control of Current Output .....	113
5.1.5.	External output on .....	115
5.1.6.	Output off by external control .....	117
5.2.	Monitor output.....	118
5.2.1.	Output voltage and output current monitor signals.....	118
5.2.2.	Operating status signal.....	119
6.	COMMUNICATION INTERFACE .....	122
6.1.	Interface Configuration .....	122
6.1.1.	Configure USB Remote Interface .....	122
6.1.2.	Configure GP-IB Interface .....	122
6.1.3.	Configure RS-232C Interface .....	123
6.1.4.	Configure Ethernet (LAN) Connection .....	124
6.1.5.	USB Remote Control Function Check .....	126
6.1.6.	Using Realterm to Establish a Remote Connection .....	126
6.1.7.	GP-IB Remote Control Function Check.....	128
6.1.8.	Socket Server Function Check .....	130
7.	MAINTENANCE .....	134
7.1.	Replacing the Dust Filter .....	134
8.	FAQ .....	135
9.	APPENDIX .....	136
9.1.	Factory default settings .....	136
9.2.	Error Messages & Messages .....	137
9.3.	LED Display Format .....	139
10.	Specifications .....	140
10.1.	360W Type I.....	140
10.2.	720W Type II.....	143
10.3.	1080W Type III.....	146
10.4.	Common .....	149
11.	PSW-A Dimensions .....	151
11.1.	360W Type I.....	151
11.2.	720W Type II.....	152
11.3.	1080W Type III.....	154

■ About the manual.

In order to be environmentally friendly and reduce waste, we are gradually discontinuing the use of paper or CD manuals that come with our products. Even if there is a description attached to the instruction manual, it may not be attached. The latest version of the instruction manual is posted on our website (<https://www.texio.co.jp/download/>).

■ About firmware version

The contents described in this document apply to PSW-Multi series main unit firmware version **2.03** or higher.

# USING THE PRODUCT SAFELY

## ■ Preface

To use the product safely, read this instruction manual to the end. Before using this product, understand how to correctly use it.



If you read this manual but you do not understand how to use it, ask us or your local dealer. After you read this manual, save it so that you can read it anytime as required.

## ■ Notes on reading this instruction manual

- ◆ The contents of this instruction manual include technical terms in part of their explanation. If you do not understand those terms, do not hesitate to ask us or your local dealer.

## ■ Pictorial indication and warning character indication

This instruction manual and product show the warning and caution items required to safely use the product. The following pictorial indication and warning character indication are provided.

<p>&lt;Pictorial indication&gt;</p> 	<p>Some part of this product or the instruction manual may show This pictorial indication. In this case, if the product is incorrectly used in that part, a serious danger may be brought about on the user's body or the product. To use the part with this pictorial indication, be sure to refer to this instruction manual.</p>
<p>&lt;Warning character Indication&gt;</p>  <p><b>WARNING</b></p>  <p><b>CAUTION</b></p>	<p>If you use the product, ignoring this indication, you may get killed or seriously injured. This indication shows that the warning item to avoid the danger is provided.</p> <p>If you incorrectly use the product, ignoring this indication, you may get slightly injured or the product may be damaged. This indication shows that the caution item to avoid the danger is provided.</p>

---

---

## USING THE PRODUCT SAFELY

---

---



### WARNING

#### ■ Do not remove the product's covers and panels

Never remove the product's covers and panels for any purpose. Otherwise, the user's electric shock or a fire may be incurred.

#### ■ Warning on using the product

The warning items given below are to avoid danger to the user's body and life and avoid the damage and deterioration of the product.

Use the product, observing the following warning and caution items.

#### ■ Warning items on power supply

- Power supply voltage

As the rated power supply voltage of the product, the range from 100 to 240 VAC can be used without being switched.

- Power cord

**Important: The attached power cord set can be used for this device only.**

- Protection fuse

If an input protection fuse is blown, the product does not operate. When the fuse is blown, the user can replace it. However, replace it correctly, observing the warning and caution items that are provided in the section of the instruction manual where the fuse replacement is explained. If the fuse is incorrectly replaced, a fire may occur.

- Changing the power supply voltage

The rated power supply voltage cannot be changed. Use the product only at the rated power supply voltage indicated on the product. Otherwise, a fire may occur. The product's rated power supply voltage is from 100 to 240 VAC. Use the product in this range. (For use at a voltage higher than 125 VAC, Please confirm the voltage ratings of the power cord.)

#### ■ Warning item on grounding

The product has the GND terminal on the panel surface to protect the user from electric shock and protect the product. Be sure to ground the product to safely use it.

---

---

## USING THE PRODUCT SAFELY

---

---



### WARNING

#### ■ Warning item on installation environment

- Operating temperature  
Use the product within the operating temperature indicated in the rating column. If the product is used with the vents of the product blocked or in high ambient temperatures, a fire may occur.
- Operating humidity  
Use the product within the operating humidity indicated in the rating column. Watch out for condensation by a sharp humidity change such as transfer to a room with a different humidity. Also, do not operate the product with wet hands. Otherwise, an electric shock or fire may occur.
- Use in a gas  
Use in and around a place where an inflammable or explosive gas or steam is generated or stored may result in an explosion and fire. Do not operate the product in such an environment.  
Also, use in and around a place where a corrosive gas is generated or spreading causes a serious damage to the product. Do not use the product in such an environment.
- Do not let foreign matter in  
Do not insert metal and flammable materials into the product from its vent and spill water on it. Otherwise, an electric shock and fire may occur.

#### ■ Warning item on abnormality while in use

If smoke or fire is generated from the product while in use, stop using the product, turn off the switch, and remove the power cord plug from the outlet. After confirming that no other devices catch fire, call the company or each sales office.

#### ■ Front Panel

Please do not lift up the product, while touching the front grille.

---

---

## USING THE PRODUCT SAFELY

---

---



### CAUTION

#### ■ Input/output terminal

Maximum input to the input terminals is specified to prevent the product from being damaged. Do not supply input, exceeding the specifications that are indicated in the "Rating" or "Caution on use" column in the instruction manual of the product. Otherwise, a product failure is caused. Also, do not supply power to the output terminals from the outside. Otherwise, a product failure is caused.

#### ■ When the product is left unused for a long time

Be sure to remove the power plug from the outlet.

---

---

#### (Calibration)

Although the performance and specifications of the product are checked under strict quality control during shipment from the factory, they may aging rate because of aging rate in its parts. It is recommended to periodically calibrate the product so that it is used with its performance and specifications stable. For consultation about the product calibration, call the dealer or the company or each sales office where you bought the product.

#### (Daily maintenance)

When you clean off the dirt of the product covers, panels, and knobs, avoid solvents such as thinner and benzene. Otherwise, paint may peel off or the resin surface may be affected.

To wipe off the covers, panels, and knobs, use a soft cloth with neutral detergent in it. During cleaning, be careful that water, detergents, and other foreign matters do not get into the product.

If a liquid or metal gets into the product, an electric shock and fire are caused. During cleaning, remove the power cord plug from the outlet.

---

---

Use the product correctly and safely, observing the above warning and caution items. Because the instruction manual indicates caution items even in individual items, observe those caution items to correctly use the product.

If you have questions or comments about the content of the instruction manual, ask us or E-Mail us.

# 1. GETTING STARTED

This chapter describes this product in a nutshell, including its main features and front / rear panel introduction. After going through the overview, please read the theory of operation to become familiar with the operating modes, protection modes and other safety considerations.

## 1.1. PSW-A Series Overview

### 1.1.1. Series lineup (Total 15 models)

This product series is equipped with five types of voltage units (30V, 80V, 160V, 250V, 800V) with different rated output voltages in three types of housings (Type I, II, III).

Model name	Type	Rated voltage	Rated current	Rated power
PSW-360L30A	I	0~30V	0~36A	360W
PSW-360L80A		0~80V	0~13.5A	
PSW-360M160A		0~160V	0~7.2A	
PSW-360M250A		0~250V	0~4.5A	
PSW-360H800A		0~800V	0~1.44A	
PSW-720L30A	II	0~30V	0~72A	720W
PSW-720L80A		0~80V	0~27A	
PSW-720M160A		0~160V	0~14.4A	
PSW-720M250A		0~250V	0~9.0A	
PSW-720H800A		0~800V	0~2.88A	
PSW-1080L30A	III	0~30V	0~108A	1080W
PSW-1080L80A		0~80V	0~40.5A	
PSW-1080M160A		0~160V	0~21.6A	
PSW-1080M250A		0~250V	0~13.5A	
PSW-1080H800A		0~800V	0~4.32A	

Models with rated voltages of 30V, 80V, and 160V are low voltage models. Also, models with rated voltages of 250V and 800V are high voltage models.

Type I  
1/6 rack size

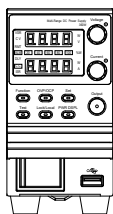

Type II  
1/3 rack size

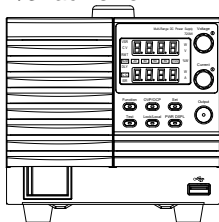

Type III  
1/2 rack size

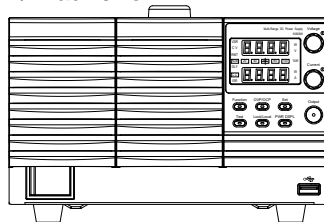

### 1.1.2. Main Features

Performance	<ul style="list-style-type: none"><li>● High performance/power</li><li>● Power efficient switching type power supply</li><li>● Low impact on load devices</li><li>● Fast transient recovery time of 1ms</li><li>● Fast output response time</li></ul> <hr/>
Features	<ul style="list-style-type: none"><li>● OVP, OCP, OHP (OTP) and tUVP protection</li><li>● Adjustable voltage and current slew rates</li><li>● Operates in three modes: CV, CC, CP</li><li>● Equipped with a bleeder circuit that can be controlled on/off</li><li>● Extensive remote monitoring and control options</li><li>● Equipped with data logger function</li><li>● Supports test scripts</li></ul> <hr/>
Interface	<ul style="list-style-type: none"><li>● Ethernet port</li><li>● Analog connector for analog voltage and current monitoring</li><li>● USB host and device port</li></ul>



### 1.1.3. Accessories

Please check the contents before using this product.

#### Standard Accessories

Part number	Description
Power cord	Varies by region and TYPE.
PSW-009 *	Output terminal covers for low voltage models
PSW-011 *	Output terminal covers for high voltage models
PSW-012 *	Output terminals for high voltage models
GTL-123 *	Test leads for low voltage models: 1x red, 1x black
GTL-240	USB Cable
PSW-004 *	Accessory kit for low voltage models: M4 terminal screws and washers x2, M8 terminal bolts, nuts and washers x2, Air filter x1, Analog control connector x1, Analog control connector lock level x1
PSW-008 *	Accessory kit for high voltage models: Air filter x1, Analog control connector x1, Analog control connector lock level x1

\* : The items and number of standard accessories vary depending on the model (low voltage or high voltage).

## Optional Accessories

Part number	Description
GET-001	Extended terminal with max. 30A
GET-002	Extended European terminal with max. 10A
PSW-001	Accessory Kit: Pin contact x10, Socket x1, Protection cover x1
GRA-410-J	Rack mount adapter (JIS)
GRA-410-E	Rack mount adapter (EIA)
GUG-001	GPIB to USB adapter
GTL-130	Test leads for high voltage modules: 1x red, 1x black
GTL-240	USB Cable
GUR-001B	RS-232 to USB adapter with #4-40 UNC rivet nut

## Download

Name	Description
Manual	User manual, Programming manual
texio_cdc*.inf	USB driver
Test Data	Test Script Data

## 1.2. Appearance

### 1.2.1. Front Panel

720W models

PSW-720\*\*\*\*A (Typell)

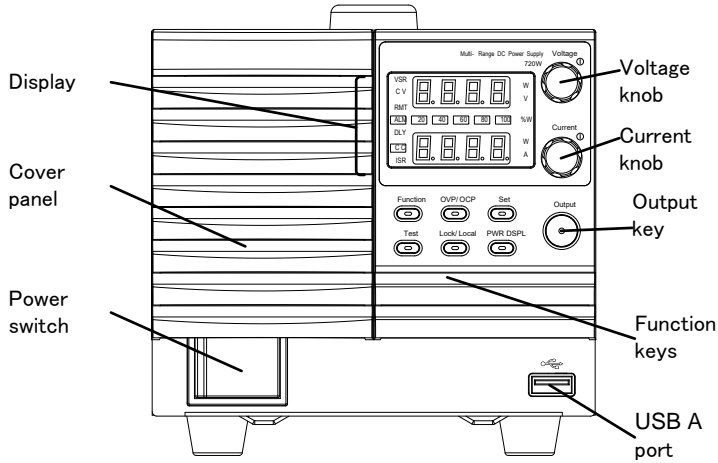

1080W, 360W models



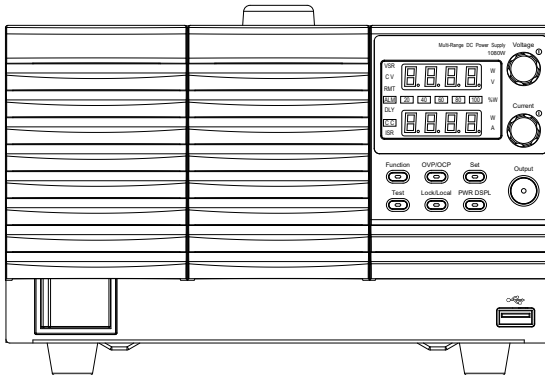

PSW-1080\*\*\*\*A (Typelll)

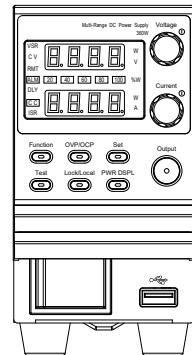



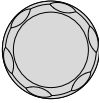

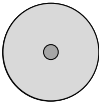
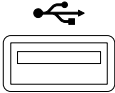
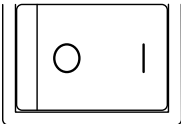
PSW-360\*\*\*\*A (Typel)



## Front panel description

No.	Name	Symbol	Description
1	Voltage Knob	<p>Voltage ①</p> 	<p>Sets the voltage.</p> <p>When pressed, the variable digit changes. Variable digits are displayed brighter than other digits.</p>
2	Current Knob	<p>Current ①</p> 	<p>Sets the current.</p> <p>When pressed, the variable digit changes. Variable digits are displayed brighter than other digits.</p>
3	Output Button	<p>Output</p> 	<p>Press to turn on the output. The Output key will light up when the output is active.</p>
4	Cover panel		<p>It is an air intake port.</p>
5	USB A port		<p>USB A port for data transfer, loading test scripts etc.</p>
6	Power Switch		<p>Used to turn the power on/off.</p>
7	Function Keys	<p>The Function keys along with the Output key will light up when a key is active.</p>	
	Function key	<p>Function</p> 	<p>The Function key is used to configure this product.</p>
	OVP/OCP key	<p>OVP/OCP</p> 	<p>Set the over current or over voltage protection levels.</p>

Set key	<p style="text-align: center;">Set</p> 	Sets the current and voltage limits.
Test key	<p style="text-align: center;">Test</p> 	Used to run customized scripts for testing.
Lock/Local key	<p style="text-align: center;">Lock/Local</p> 	Panel key lock and unlock. Locks prevent accidental changes to panel settings.
PWR DSPL key	<p style="text-align: center;">PWR DSPL</p> 	<p>Switch the display between V/A and V/W or A/W.</p> <p>For V/W, press the voltage knob; for A/W, press the current knob.</p>
8 Display	Displays the operating status of this product.	
	VSR	Voltage slew rate function enabled
	c v	CV operation status
	RMT	Remote control status
	<b>ALM</b>	Alarm occurrence status
	DLY	Output delay function enabled
	<b>CC</b>	CC operation status
	ISR	Current slew rate function enabled
	<div style="display: flex; justify-content: space-around; align-items: center;"> <div style="border: 1px solid black; padding: 2px 5px;">20</div> <div style="border: 1px solid black; padding: 2px 5px;">40</div> <div style="border: 1px solid black; padding: 2px 5px;">60</div> </div> <div style="display: flex; justify-content: space-around; align-items: center; margin-top: 5px;"> <div style="border: 1px solid black; padding: 2px 5px;">80</div> <div style="border: 1px solid black; padding: 2px 5px;">100</div> <div>% W</div> </div>	Displays power output as a bar.

### 1.2.2. Rear Panel

#### Low voltage 720W models

PSW-720M160A, PSW-720L80A, PSW-720L30A (Type II)

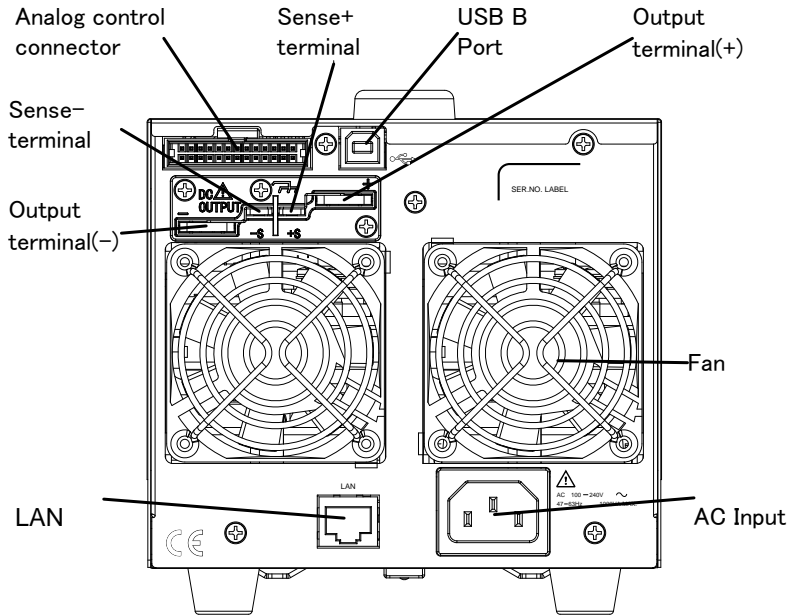

#### Low voltage 1080W, 360W models

PSW-1080M160A,  
PSW-1080L80A,  
PSW-1080L30A  
(Type III)

PSW-360M160A,  
PSW-360L80A,  
PSW-360L30A  
(Type I)

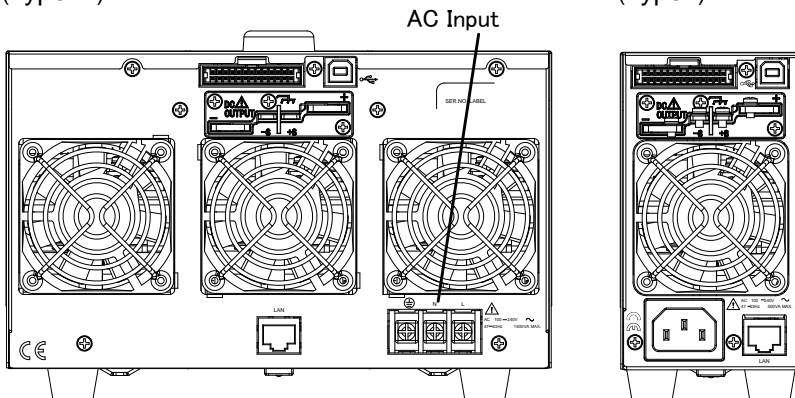

High voltage 720W models

PSW-720H800A, PSW-720M250A (Type II)

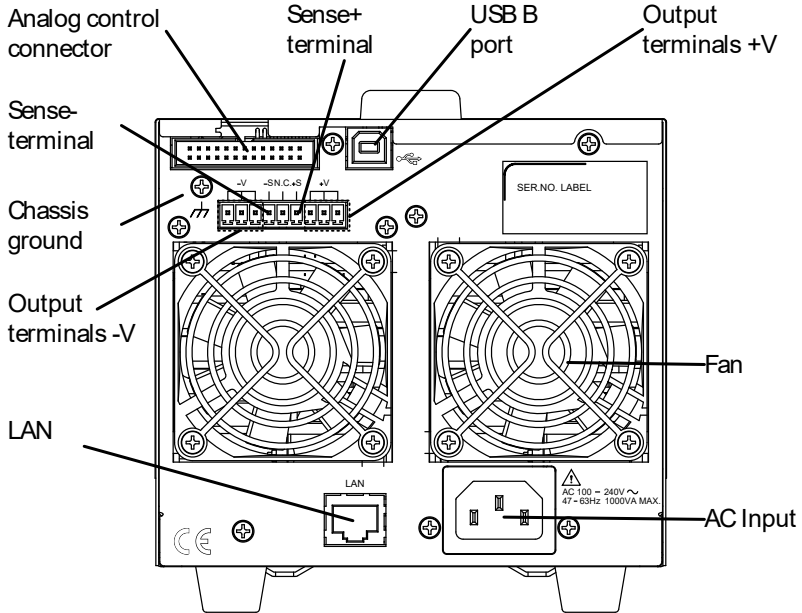



High voltage 1080W, 360W models

PSW-1080H800A,  
PSW-1080H250A  
(Type III)

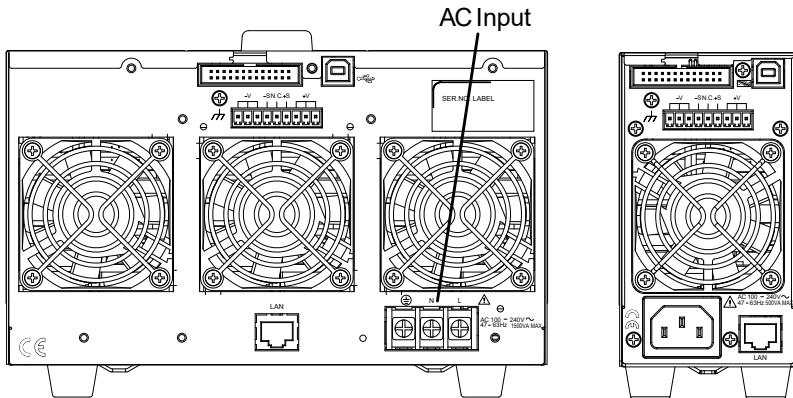
PSW-360H800A,  
PSW-360M250A  
(Type I)

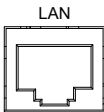
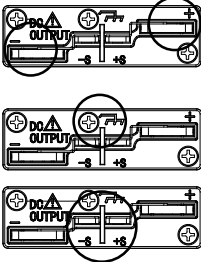
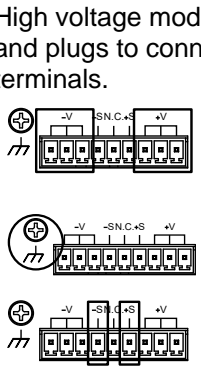
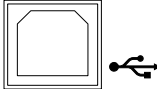

## Rear panel description

No.	Name	Symbol	Description
1	LAN Port		The ethernet port is used for remote control and digital monitoring from a controller.
2	Output Terminals (Low-volt model)		Positive (+) and negative (-) output terminals. Chassis ground Sense (-S) and Sense (+S) terminals.
	Output Terminals (High-volt model)		High voltage models use 9-pin connectors and plugs to connect output and sense terminals. Positive (V+) and negative (V-) output terminals (3 of each). Chassis ground Sense (-S) and Sense (+S) terminals.
3	USB B port		The USB B port is used for remote control.
4	Analog control connector		Standard 26 pin MIL connector For wiring to this connector, use the included analog control connector (OMRON XG5 26 pin). For usage instructions, refer to page <a href="#">106</a> . When this connector is not used, please keep this connector cover attached.
5	Fans		Temperature controlled fans



Note



6 Line Voltage Input  
360W, 720W  
models

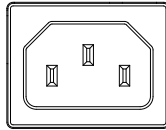

Voltage Input: 100~240  
VAC  
Line frequency: 50Hz/60  
Hz

Line Voltage Input  
1080W models

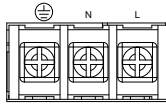

### 1.3. Theory of Operation

The theory of operation chapter describes the basic principles of operation, protection modes and important considerations that must be taken into account before use.

#### 1.3.1. Operating Area Description

This product is regulated DC power supplies with a high voltage and current output. These operate in CC or CV mode within a wide operating range limited only by the output power.

The operating area of each power supply is determined by the rated output power as well as the voltage and current rating. For example, the operating area and rated power output for the PSW-360L30A (360W) is shown below.

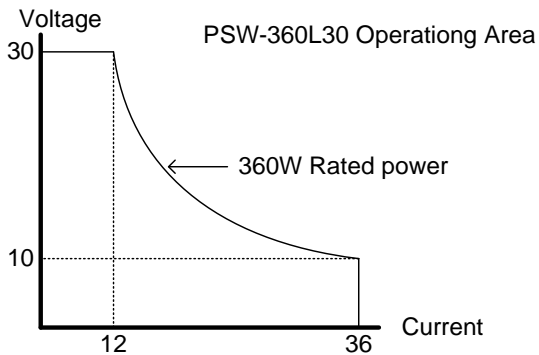

When the output power (output voltage x output current) of this product is less than the rated power, it operates as a general constant voltage, constant current power supply.

When the output power (output voltage x output current) of this product is greater than the rated power, the output of the power supply is limited to the rated power. In this case, the output voltage and output current depend on the load.

The power limit value can be set within the rated power for this product. This allows the output of this product to operate within the set power limit value.

Below is a comparison of the operating areas of each power supply.

### 30V model operating area

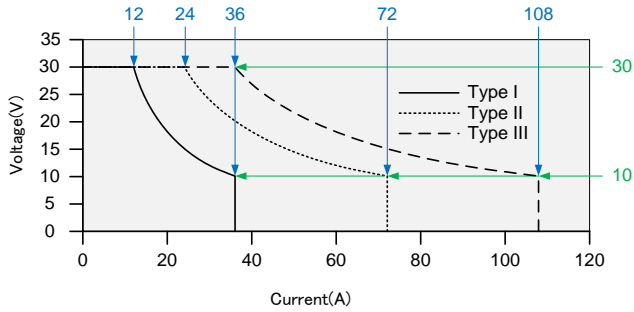

### 80V model operating area

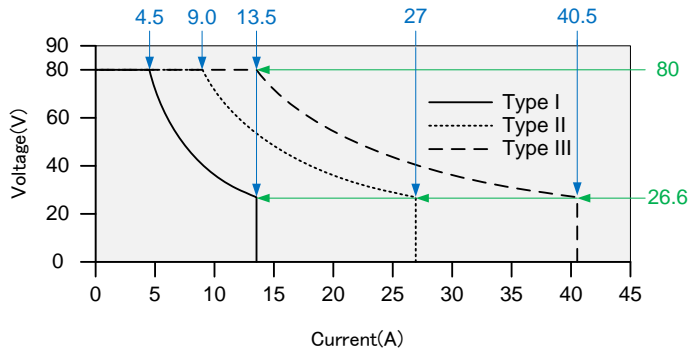

### 160V model operating area

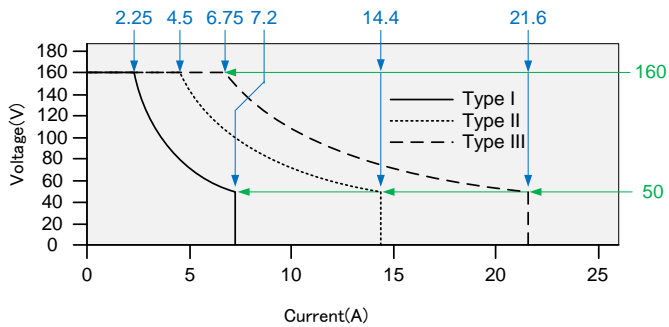

### 250V model operating area

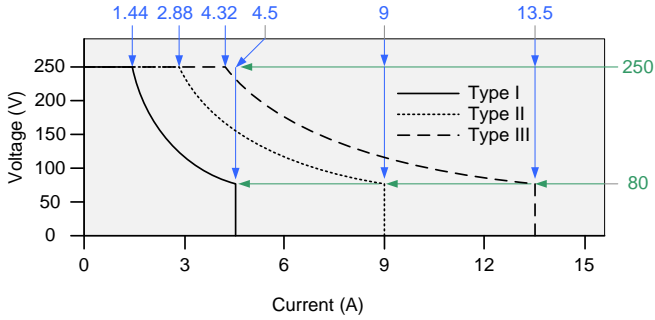

### 800V model operating area

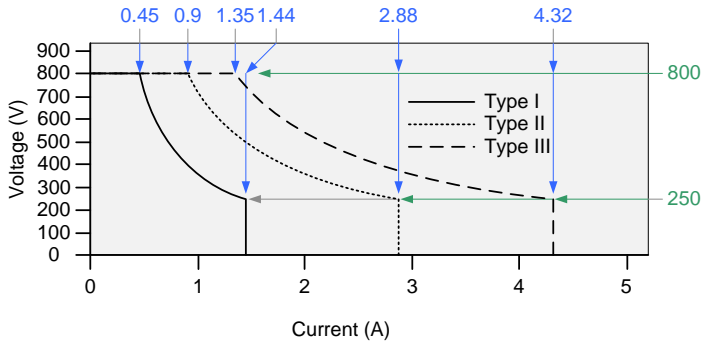

### 1.3.2. CC and CV Mode

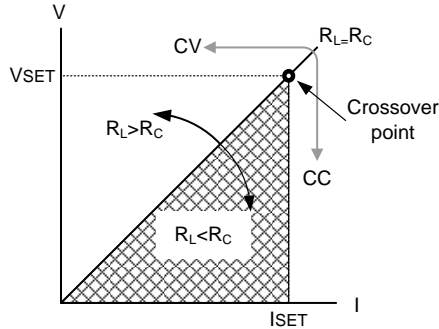

When the power supply is operating in constant current mode (CC) a constant current will be supplied to the load. When in constant current mode the voltage output can vary, whilst the current remains constant. When the load resistance increases to the point where the current limit (ISET) can no longer be sustained the power supply switches to CV mode. The point where the power supply switches modes is the crossover point.

When the power supply is operating in CV mode, a constant voltage will be supplied to the load, whilst the current will vary as the load varies. At the point that the load resistance is too low to maintain a constant voltage, the power supply will switch to CC mode and maintain the set current limit.

The conditions that determine whether the power supply operates in CC or CV mode depends on the set current (ISET), the set voltage (VSET), the load resistance (RL) and the critical resistance (RC). The critical resistance is determined by  $VSET/ISET$ . The power supply will operate in CV mode when the load resistance is greater than the critical resistance. This means that the voltage output will be equal to the VSET voltage but the current will be less than ISET. If the load resistance is reduced to the point that the current output reaches the ISET level, the power supply switches to CC mode.

Conversely the power supply will operate in CC mode when the load resistance is less than the critical resistance. In CC mode the current output is equal to ISET and the voltage output is less than VSET.

### 1.3.3. Slew Rate

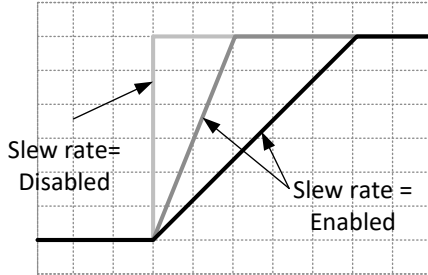

This product has selectable slew rates for CC and CV mode. Slew rate settings are divided into High-Speed Priority and Slew Rate Priority. High-Speed Priority mode disables slew rate settings for CC or CV mode. Slew Rate Priority mode allows for user adjustable slew rates for CC or CV mode. The rising and falling slew rate can be set independently. Please refer to page 66 for the setting method.

### 1.3.4. Bleeder Control

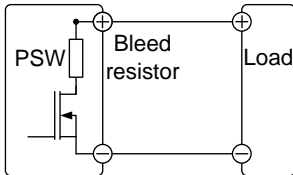

The output section of this product is equipped with a bleeder circuit that includes a bleed resistor, and this circuit can be turned on/off. Please refer to page 69 for the setting method.

The bleeder circuit is designed to dissipate power from the power supply filter capacitor when the power supply is turned off and the load is disconnected. Without a bleeder circuit, power will remain charged to the filter capacitor for some time, potentially creating a dangerous condition.

In addition, the bleeder circuit acts as a minimum voltage load, allowing smoother voltage variation of the power supply.

The bleeder circuit can be turned on or off using this product settings.

It sinks current from an external voltage source depending on the settings of the bleeder circuit.



Note

By default, the bleeder circuit is on. For battery charging applications, be sure to turn off the bleeder circuit as it can discharge the connected battery when the unit is off.

PSW-360L30A sink current

Vout (V)	Bleeder ON (A)	Bleeder OFF (mA)
1	1.455	0.000
3	1.733	0.000
5	1.559	0.002
10	1.123	0.009
15	0.715	0.014
20	0.471	0.021
25	0.353	0.031
30	0.267	0.038

PSW-360L80A sink current

Vout (V)	Bleeder ON (A)	Bleeder OFF (mA)
5	0.640	0.002
10	0.589	0.009
20	0.488	0.015
30	0.387	0.026
40	0.292	0.032
50	0.224	0.045
60	0.188	0.058
80	0.140	0.084

PSW-360M160A sink current

Vout (V)	Bleeder ON (A)	Bleeder OFF (mA)
10	0.173	0.009
20	0.164	0.017
40	0.146	0.034
60	0.128	0.057
80	0.112	0.076
100	0.101	0.095
130	0.093	0.128
160	0.088	0.207

PSW-360M250A sink current

Vout (V)	Bleeder ON (A)	Bleeder OFF (mA)
10	0.158	0.031
30	0.143	0.098
50	0.129	0.164
80	0.107	0.267
100	0.092	0.333
150	0.061	0.508
200	0.463	0.697
250	0.035	0.961

PSW-360H800A sink current

Vout (V)	Bleeder ON (A)	Bleeder OFF (mA)
20	0.061	0.056
50	0.058	0.138
100	0.054	0.274
200	0.046	0.550
300	0.037	0.823
400	0.029	1.097
600	0.020	1.653
800	0.015	2.214

The sink current (Bleeder ON) for other models (720W, 1080W) is doubled (720W) or tripled (1080W) for each voltage model.



### 1.3.5. Internal Resistance

This product can set the internal resistance of the output. (Internal Resistance Setting, refer to page 61).

When the internal resistance is set it can be seen as a resistance in series with the positive output terminal. This allows this product to simulate power sources that have internal resistances such as lead acid batteries.

Model	Internal Resistance Range ( $\Omega$ )
PSW-360L30A	0.000 ~ 0.833
PSW-720L30A	0.000 ~ 0.417
PSW-1080L30A	0.000 ~ 0.278
PSW-360L80A	0.000 ~ 5.926
PSW-720L80A	0.000 ~ 2.963
PSW-1080L80A	0.000 ~ 1.975
PSW-360M160A	0.000 ~ 22.222
PSW-720M160A	0.000 ~ 11.111
PSW-1080M160A	0.000 ~ 7.407
PSW-360M250A	0.00 ~ 55.55
PSW-720M250A	0.00 ~ 27.77
PSW-1080M250A	0.00 ~ 18.51
PSW-360H800A	0.0 ~ 555.5
PSW-720H800A	0.0 ~ 277.8
PSW-1080H800A	0.0 ~ 185.1

### 1.3.6. Protection function

This product has many protection features. When any protection function is activated, the ALM icon on the display lights up. For details on how to set up protection functions, refer to

OVP	Overvoltage protection (OVP) prevents a high voltage from damaging the load. Refer to page <a href="#">41</a> .
OCP	Overcurrent protection (OCP) prevents high current from damaging the load. Refer to page <a href="#">41</a> .
OHP (OTP)	Overheat (Over temperature) protection protects this product from overheating.
tUVP	Output voltage tracking low voltage protection prevents load damage due to voltage drop. Refer to page <a href="#">92</a> .
Alarm output	Alarms are output via the analog control connector. The alarm output is an isolated open-collector photo coupler output. Refer to page <a href="#">119</a> .

### 1.3.7. Considerations

The following situations should be taken into consideration when using this product.

Inrush current	When the power supply switch is first turned on, an inrush current is generated. Ensure there is enough power available for the power supply when first turned on, especially if a few units are turned on at the same time.
 Caution	Please wait at least 15 seconds between turning the power on/off using the power switch or external breaker. Continuously turning the power switch on and off will cause the inrush current protection circuit to fail and shorten the life of the input fuse and power switch.
Pulsed or Peaked loads	When the load has current peaks or is pulsed, it is possible for the maximum current to exceed the mean current value. This product ammeter only indicates mean current values, which means for pulsed current loads, the actual current can exceed

the indicated value. For pulsed loads, the current limit must be increased, or a power supply with a greater capacity must be chosen. As shown below, a pulsed load may exceed the current limit and the indicated current on the power supply ammeter.

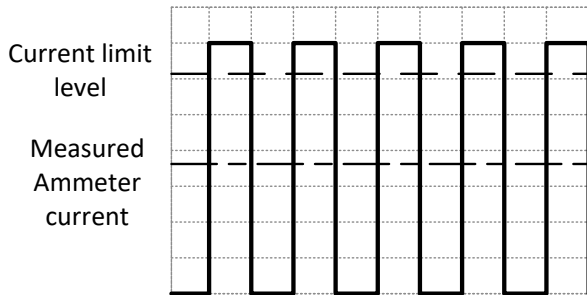

Reverse Current:  
Regenerative load

When the power supply is connected to a regenerative load such as a transformer or inverter, reverse current will feed back to the power supply. This product cannot absorb reverse current. For loads that create reverse current, connect a resistor in parallel (dummy load) to the power supply to bypass the reverse current.

To calculate the resistance for the dummy resistor,  $R_D$ , first determine the maximum reverse current,  $I_R$ , and determine what the output voltage,  $E_O$ , will be.

$$R_D(\Omega) \leq E_O(V) \div I_R(A)$$

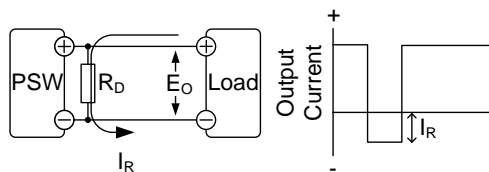

Note

The current output will decrease by the amount of current absorbed by the dummy resistor.

Ensure the resistor used can withstand the power capacity of the power supply/load.

Reverse Current:  
Accumulative energy.

When the power supply is connected to a load such as a battery, reverse current may flow back to the power supply. To prevent damage to this product, use a reverse-current-protection diode in series between

this product and load.

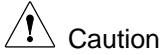
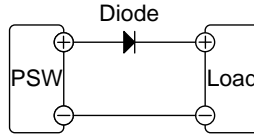

Caution

Ensure the reverse withstand voltage of the diode is able to withstand 2 times the rated output voltage of the power supply and the forward current capacity can withstand 3 to 10 times the rated output current of the power supply.

When the diode is used to limit reverse voltage, remote sensing cannot be used.

When connecting a charged load, be careful of electric shock and sparks.

### 1.3.8. Output grounding

The output terminals of this product are isolated with respect to the protective grounding terminal. The insulation capacity of the load, the load cables and other connected devices must be taken into consideration when connected to the protective ground or when floating.

Floating

As the output terminals are floating, the load and all load cables must have an insulation capacity that is greater than the isolation voltage of this product.

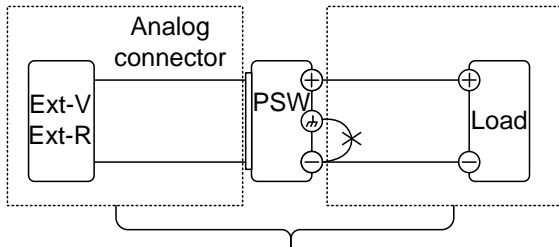

(-----) Insulation capacity  $\geq$  isolation voltage of power supply



WARNING

When the insulation capacity of the load and load cables is not greater than the isolation voltage of this product, electric shock may occur.

When analog controlling this device using external

voltage control, external resistance control, etc., the control signal should be floating instead of grounded. If it is grounded, the output will short-circuit and cause an accident.

### Grounded output terminal

When the positive or negative terminal is connected to the protective ground terminal, the insulation capacity needed for the load and load cables is greatly reduced. The insulation capacity only needs to be greater than the maximum output voltage of this product with respect to ground.

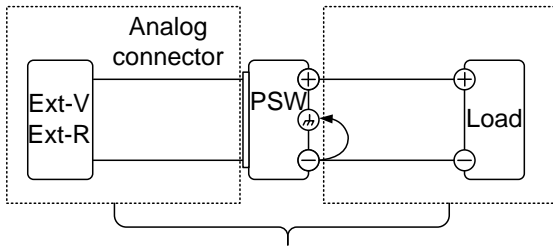

(.....) Insulation capacity  $\geq$  voltage of power supply with respect to ground



### Caution

When using external voltage control, do not ground the external voltage terminal as this will create a short circuit.

When output floating is not required, connect either output terminal to GROUND for safety.

## 2. OPERATION

### 2.1. Set Up

#### 2.1.1. Line Voltage Connection: 1080W Models

The 1080 models use a universal power input that can be used with 100 and 200 VAC systems. To connect or replace the power cord, use the procedure below:



Warning

The following procedure should only be attempted by competent persons.

Ensure the AC power cord is not connected to this product.

How to remove AC cord

steps Removal instructions

- 1 Turn off the power switch.
- 2 Remove the cover protecting the AC cord.
- 3 Remove the screws (2 places) that secure the cover protecting the power terminal.
- 4 Slide the cover off the AC terminals.
- 5 Remove the AC power cord wires.

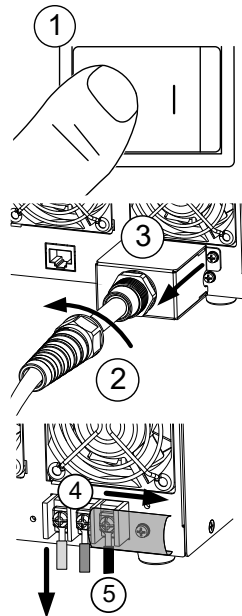

## How to attach the AC cord

### steps Installation procedure

- 1 Connect the AC power cord wires to the AC input terminals.

White/Blue → Neutral (N)

Green/Green-yellow → GND (⊕)

Black/Brown → Line (L)

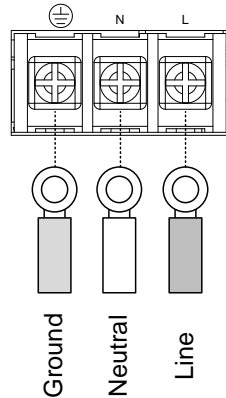

- 2 Set the cover back over the AC terminals.

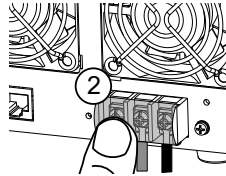

- 3 Secure the AC terminal protection cover with screws.



- 4 Rotate the AC cord cover to secure it in place.

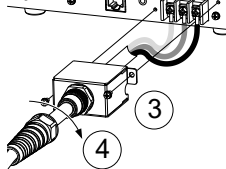

### 2.1.2. Filter Installation

This product has a small filter that must first be inserted under the control panel before operation. The small filter must be inserted for all power modules.

#### steps Step instructions

- 1 Insert the small filter in the open area under the control panel.



- 2 The unit is now ready to power up.

### 2.1.3. Power Up

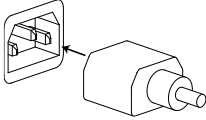
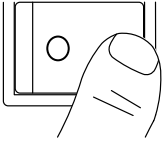
steps	Step instructions
1	<p>360W, 720W model: Connect the power cord to the AC inlet on the back panel.</p>  <p>1080W model: Connect the power cord to the AC input terminal on the back panel.</p> <p>Refer to page 28.</p>
2	<p>Press the POWER switch. If used for the first time, the default settings will appear on the display, otherwise this product recovers the state right before the power was last turned OFF.</p>  <p>For default configuration settings, refer to page 136.</p>



#### Caution

When turned off, it takes approximately 15 seconds for the power to completely turn off.

Before turning on the power again, please wait until the display disappears and this product is completely turned off (about 15 seconds).

### 2.1.4. Regarding load line selection

Before connecting the output terminals to a load, the wire gauge of the cables should be considered.

It is essential that the current capacity of the load cables is adequate. The rating of the cables must equal or exceed the maximum current rated output of this product.

Wire Gauge	Recommended wire gauge	
	SQ size / mm <sup>2</sup>	Allowable current
AWG 26	0.12 / 0.128	3 A
AWG 24	0.2 / 0.205	5 A
AWG 22	0.3 / 0.324	7 A
AWG 20	0.5 / 0.519	11 A
AWG 18	0.75 / 0.823	14 A
AWG 16	1.25 / 1.31	19 A
AWG 14	2 / 2.08	27 A



AWG 12	3.5 / 3.31	37 A
AWG 10	5.5 / 5.26	49 A
AWG 8	8 / 8.37	61 A
AWG 6	14 / 13.3	88 A
AWG 4	22 / 21.15	115 A
AWG 2	38 / 33.63	162 A
AWG 1	38 / 42.41	162 A
AWG 1/0	60 / 53.49	219 A
AWG 2/0	60 / 67.42	219 A
AWG 3/0	80 / 85.3	269 A
AWG 4/0	100 / 107.2	298 A

The maximum temperature rise of the wire is no more than 60 °C above ambient temperature. Keep the ambient temperature below 30°C.

### 2.1.5. Output Terminals: Low voltage model

Before connecting the output terminals to the load, first consider whether voltage sense will be used, the gauge of the cable wiring and the withstand voltage of the cables and load.

The output terminals can be connected to load cables using M4 sized screws or M8 sized bolts.



Warning

Dangerous voltages:

Before wiring the output terminals of this product, be sure to make sure that the power is turned off. Failing to do so may lead to electric shock.

steps	Step instructions
-------	-------------------

1	Turn the power switch off.
---	----------------------------

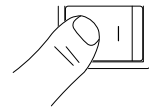

2	Remove the output terminal cover.
---	-----------------------------------

Refer to page [32](#).

3	If necessary, screw the chassis ground terminal to either the positive or negative terminal. Refer to the grounding chapter for details. (Refer to page <a href="#">26</a> .)
---	---

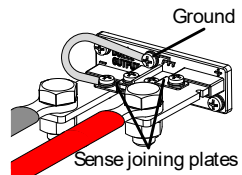

4	Choose a suitable wire gauge for the load cables.
---	---

Refer to page [30](#).

- 5 Choose a suitable crimp terminal for the terminals.
- 6 When using voltage sense, remove the sense terminal joining plates and connect sensing wires to the load(s). Refer to page 49.
- 7 Connect the positive load cable to the positive output terminal and the negative cable to the negative output terminal.
- 8 Reattach the output terminal cover. Refer to page 32.

### voltage sense wiring

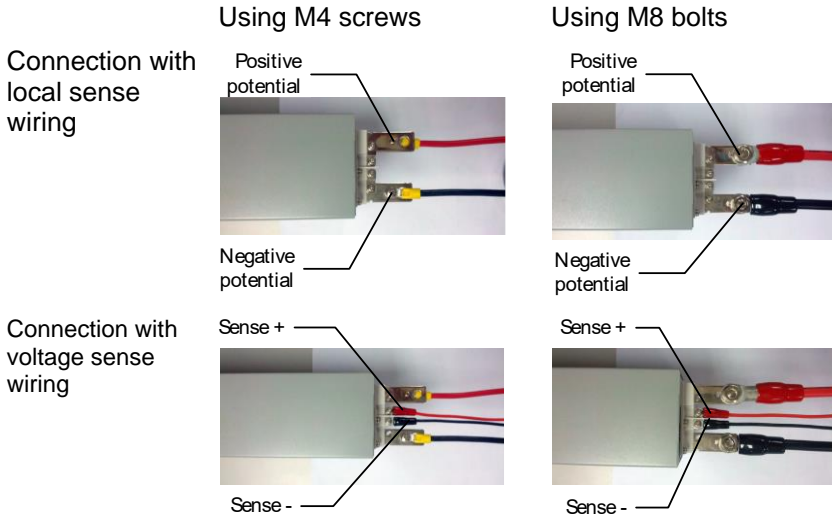

### 2.1.6. Attaching output terminal cover: Low voltage model

steps	Step instructions
1	Remove the screws securing the top and bottom covers. Slide the top cover to separate the top and bottom covers.
2	Align the tab on the bottom cover with the U-shaped notch at the base of the output terminal.
3	Place the top cover on top of the bottom cover by sliding it backwards.

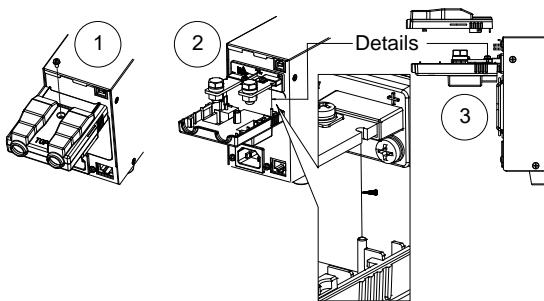

- 4 Slide the top cover to integrate with the bottom cover.
- 5 When the top and bottom covers are flush, re-insert the screw that was removed in step 1.

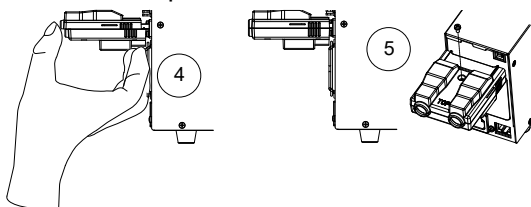

Note

Reverse the procedure to remove the terminal covers.

### 2.1.7. Output Terminals: High voltage model

High voltage models use the supplied 9-pin socket for output voltage and sense connections.

Before connecting the output terminal to the load, first check whether you use voltage sensing, the gauge of the cable wiring, and the withstand voltage of the cable and load.



Warning

Dangerous voltages. Ensure that the power to the instrument is disabled before handling this product output terminals. Failing to do so may lead to electric shock.

Please note the wire gauge used and the capacity of the plug/socket. If necessary, connect multiple cables to the connector.

**Output Connector Overview**

When using the output connector make sure the wires that are used follow the following guidelines:

Wire gauge: AWG 26 to AWG 16

Strip length: 6.5mm // 0.26 in.

Current rating: 10A

Insulation withstand voltage: >2000MΩ DC500V

Operation Temperature: -40°C to +105°C

**Output Connector Pinout**

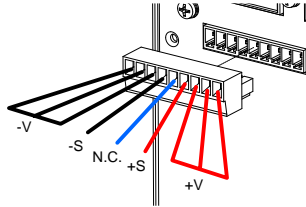

- V: -V terminals (x3)
- S: -Sense terminal
- NC: Not connected
- +S: +Sense terminal
- +V: +V terminals (x3)

**Wiring the Connector Plug**

- a: Loosen the terminal you want to use counterclockwise and open the output terminal opening.
- b: Strip at least 7mm of the insulation off the wire and insert it into the output terminal opening.
- c: Tighten the output terminal opening by turning the terminal clockwise.

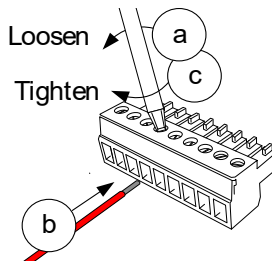

**steps Step instructions**

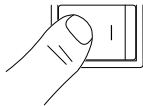
- 1 Turn the power switch off. 
- 2 Remove the output terminal cover. Refer to page 35.
- 3 Choose a suitable wire gauge for the load cables. Refer to page 30.
- 4 Strip ~7mm from one end of each load cable.
- 5 Connect the positive load cable to one of the +V pins and the negative cable to one of the -V pins.

- 6 When using local sense, connect the -S pin to a -V pin, and connect the +S pin to a +V pin.

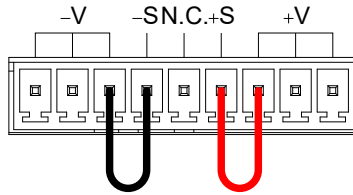

- 7 When not using local sense, see the remote sense section to wire the sense terminals for remote sensing. Refer to page 49.
- 8 If necessary, connect the chassis ground terminal to either the -V or +V pin. See the grounding chapter for details. Refer to page 26.

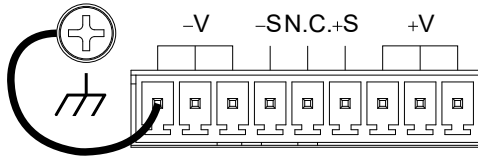

- 9 Reattach the output terminal cover. Refer to page 35.

Local sense wiring

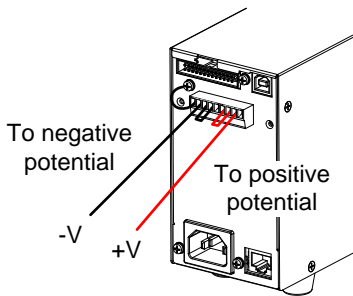

Remote sense wiring

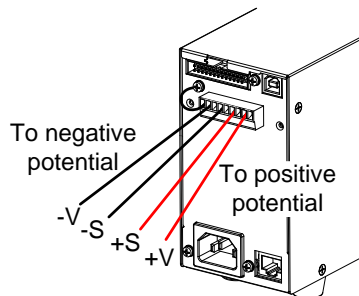

### 2.1.8. Attaching output terminal cover: High voltage model

steps	Step instructions
-------	-------------------

- |   |   |
|---|---|
| 1 | Screw the bottom cover onto the rear panel using the two M4 screws. |
|---|---|

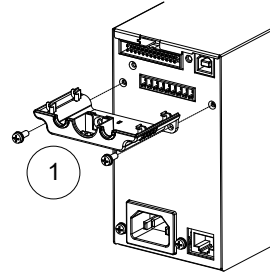

- |   |  |
|---|--|
| 2 | Slide the top cover over the bottom cover. |
|---|--|

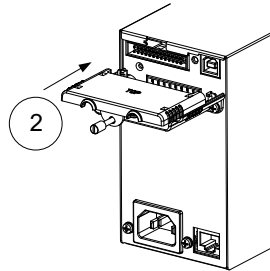

- |   |   |
|---|---|
| 3 | Finally, secure the top and bottom covers using the screw in the center of the top cover. |
|---|---|

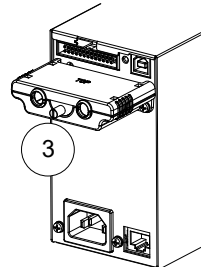

Reverse the procedure to remove the terminal covers.



Note

Reverse the procedure to remove the terminal covers.

### 2.1.9. Using the Rack Mount Kit

This product has an optional Rack Mount Kit.  
Part number: [JIS] GRA-410-J, [EIA] GRA-410-E

A single rack mount kit can accommodate six 360W models, three 720W models, or two 1080W models.

## 2.1.10. Using the Voltage and Current knob

This product use voltage or current knobs to set parameter values. Press the voltage or current knob to select the setting digit of the parameter value.

**Example** Use the Voltage knob to set a voltage of 10.05 V.

**steps**    **Step instructions**

- 1 Press the voltage knob repeatedly until the 0.01 V digit is highlighted.

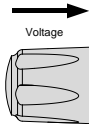

- 2 Turn the voltage knob and set 0.05V.

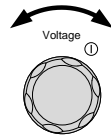

- 3 Press the voltage knob repeatedly until the 10.00 V digit is highlighted.

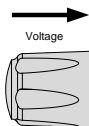

- 4 Turn the voltage knob and set 10.05V.

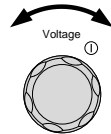







Note

While the Set key on the front panel is lit, the voltage/current display shows the set value.

When the output is on, press the Set key to display the set value and operate.

### 2.1.11. Reset to Factory Default Settings

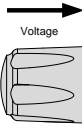
This product can be reset to factory default settings. For factory default settings, see page 136.

steps	Step instructions	
1	Press the Function key. The Function key will light up.	<p>Function</p> 
2	The display should show F-01 on the top and the configuration setting for F-01 on the bottom.	
3	Rotate the Voltage knob to change the F setting to F-88 (Factory Set Value).	<p>Voltage</p> 
4	Use the Current knob to set the F-88 setting to 1 (Return to factory settings).	<p>Current</p> 
5	Press the voltage knob to determine the setting. When the settings are confirmed, "ConF" will be displayed.	<p>Voltage</p> 
6	Press the Function key again to exit. The function key light will turn off.	<p>Function</p> 

### 2.1.12. Verifying firmware version and system information

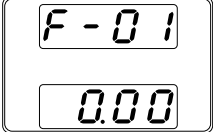
steps	Step instructions	
1	Press the Function key. The Function key will light up.	<p>Function</p> 
2	The display should show F-01 on the top and the configuration setting for F-01 on the bottom.	



- 3 Rotate the Voltage knob to change the F setting to F-89 (Show Version).

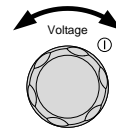

- 4 Turn the current knob to display the firmware version and system information.

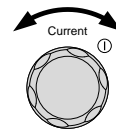

F-89	0-XX	Firmware version number
	1-XX	Firmware version number
	2-XX	Firmware build: Year
	3-XX	Firmware build: Year
	4-XX	Firmware build: Month
	5-XX	Firmware build: Day
	6-XX	Keyboard CPLD version number
	7-XX	Keyboard CPLD version number
	8-XX	Analog control CPLD version number
	9-XX	Analog control CPLD version number
	A-XX	Control Board Version number
	B-XX	Reserved
	C-XX	Kernel build: Year
	D-XX	Kernel build: Year
	E-XX	Kernel build: Month
	F-XX	Kernel build: Day
	G-XX	Test Command Version number
	H-XX	Test Command Version number
	I-XX	Test Command build: Year
	J-XX	Test Command build: Year
	K-XX	Test Command build: Month
	L-XX	Test Command build: Day
	M-XX	USB Driver version number
	N-XX	USB Driver version number

- 5 Press the Function key again to exit. The function key light will turn off.



Example Firmware information: Ver1.50, 2014/01-13

0-01		
1-50	Version number	1.50
2-20		
3-14	Build: Year	2014
4-01		
5-13	Build: Month - Day.	01-13
Example	Keyboard CPLD information: 0x030c	
6-03	Version number	030c
7-0c		
Example	Analog control CPLD information: 0x0427	
8-04	Version number	0427
9-27		
Example	Control Board information: XX	
A-XX	Version number	XX
Example	Kernel information: 2013/03-22	
C-20	Build: Year	2023
D-13		
E-03		
F-22	Build: Month - Day.	03-22
Example	Test Command information: V01:00, 2011/08-01	
G-01	Version number	1.00
H-00		
I-20	Build: Year	2011
J-11		
K-08	Build: Month - Day.	08-01
L-01		
Example	USB Driver information: V02.01:	
M-02	Version number	2.01
N-01		

## 2.2. Basic Operation

This section describes the basic operations required to operate this product.

Before operating this product, please refer to the Getting Started chapter (page 5).

### 2.2.1. Setting OVP/OCP Levels

For most models the OVP level has a selectable range of approximately 10% to 110% of the rated output voltage. Likewise, the OCP level for most models has a selectable range of approximately 10%~ 110% of the rated output current. The OVP and OCP level is set to the maximum by default. The OCP level can also be turned off.

Note that the actual setting range differs for each model.

When either protection function is activated, ALM will be displayed on the panel display.

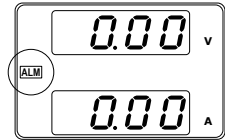

Before setting the OVP or OCP level:

Ensure the load is not connected.

Ensure the output is set to off.

#### How to set the OVP/UVP values

steps	Step instructions
1	Press the OVP/OCP key. The OVP/OCP key lights up.
2	The OVP setting will be displayed on the top and the OCP setting (or OFF) will be displayed on the bottom.
3	Use the Voltage knob to set the OVP level.
4	Use the Current knob to set the OCP level, or to turn OCP off.



OVP/OCP

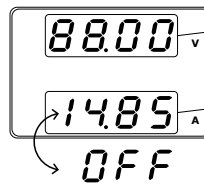

OVP Setting

OCP Setting



Voltage





Current



- 5 Press OVP/OCP again to exit.  
The OVP/OCP indicator will turn off.

OVP/OCP



### Power switch trip setting



Note

The power switch of this product is not a trip type switch. Even if this setting is enabled, the power switch will not turn off.

steps	Step instructions	
1	While holding down the Function key, turn on the Power Switch.	Refer to page 76.
2	Operate the voltage knob and set the top of the Display Indicators light to "F-95".	<p>Voltage ①</p>
3	Operate the current knob to set the lower part of the Display Indicators light to "0 or 1". "0" setting: Power switch trip is Enable "1" setting: Power switch trip is disabled	<p>Current ①</p>
4	Press the Voltage knob to determine. When the settings are confirmed, "ConF" will be displayed.	<p>Voltage</p>
5	Press the Function key again to exit. The function key light will turn off.	<p>Function</p>

### Clear OVP/OCP

steps	Step instructions	
1	To clear protection activity notifications, press and hold the OVP/OCP key for 2 seconds.	<p>OVP/OCP</p>



Note

Only applicable when the power switch trip setting (F-95: 1) is disabled.

### 2.2.2. Set to CV Mode



When setting the power supply to constant voltage mode, a current limit must also be set to determine the crossover point. When the current exceeds the crossover point, the mode switches to CC mode. For details about CV operation, refer to page 19.

CC and CV mode have two selectable slew rates: High Speed Priority and Slew Rate Priority. High Speed Priority will use the fastest slew rate for this product while Slew Rate Priority will use a user-configured slew rate.

Before setting this product CV mode, please ensure the following:

The output is off.

The load is connected.

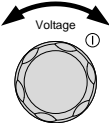
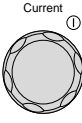
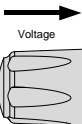
steps	Step instructions	
1	Press the Function key. The Function key will light up.	
2	The display should show F-01 on the top and the configuration setting for F-01 on the bottom.	
3	Rotate the Voltage knob to change the F setting to F-03 (V-I Mode Slew Rate Select).	
4	Use the Current knob to set the F-03 setting. Set F-03 to 0: CV High Speed Priority Set F-03 to 2: CV Slew Rate Priority	
5	Press the Voltage knob to determine the configuration setting. When the settings are confirmed, "ConF" will be displayed.	
6	When CV Slew Rate Priority was chosen as the operating mode (Set F-03 to 2), repeat steps 3~5 to set F-04 (Rising Voltage Slew Rate) and the F-05 (Falling Voltage Slew Rate) and save.	

Voltage model	Slew rate setting range
30V	0.1V/s ~ 60V/s
80V	0.1V/s ~ 160V/s
160V	0.1V/s ~ 320V/s

250V                      0.1V/s ~ 500.0V/s  
800V                      1V/s ~ 1600V/s

7 Press the Function key again to exit the configuration settings.

Function



The function key light will turn off.

8 Use the Current knob to set the current limit (crossover point).

Current



Voltage

9 Use the Voltage knob to set the voltage.



Note

When the set value is displayed on the display, the Set key lights up.

If the knob does not respond when turned, check the Set key.

10 Press the Output key.  
The Output key becomes illuminated.

Output

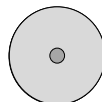

The display indicator's CV display and power bar will light up.



Note

When the output is turned on, the display becomes the output value. When the Set key is pressed, the display will show the set value.

For more information on the Normal Function Settings (F-00 ~ F-61, F-88~F-89) refer to page [66](#).



### 2.2.3. Set to CC Mode

When setting the power supply to constant current mode, a voltage limit must also be set to determine the crossover point. When the voltage exceeds the crossover point, the mode switches to CV mode. For details about CC operation, refer to page 19. CC and CV mode have two selectable slew rates: High Speed Priority and Slew Rate Priority. High Speed Priority will use the fastest slew rate for this product while Slew Rate Priority will use a user-configured slew rate.

Before setting this product CC mode, please ensure the following:

The output is off.

The load is connected.

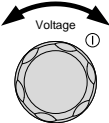
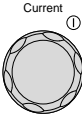
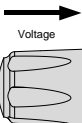
steps	Step instructions	
1	Press the Function key. The Function key will light up.	
2	Press the Function key. The Function key will light up.	
3	Rotate the Voltage knob to change the F setting to F-03 (V-I Mode Slew Rate Select).	
4	Use the Current knob to set the F-03 setting. Set F-03 to 1: CC High Speed Priority Set F-03 to 3: CC Slew Rate Priority	
5	Press the Voltage knob to determine the configuration setting. When the settings are confirmed, "ConF" will be displayed.	
6	When CC Slew Rate Priority was chosen as the operating mode (Set F-03 to 3), repeat steps 3~5 to set F-06 (Rising Current Slew Rate) and the F-07 (Falling Current Slew Rate) and save.	
Model	Slew rate setting range	
PSW-360L30A	0.01A/s ~ 72.00A/s	
PSW-720L30A	0.1A/s ~ 144.0A/s	
PSW-1080L30A	0.1A/s ~ 216.0A/s	

PSW-360L80A	0.01A/s ~ 27.00A/s
PSW-720L80A	0.01A/s ~ 54.00A/s
PSW-1080L80A	0.01A/s ~ 81.00A/s
PSW-360M160A	0.01A/s ~ 14.40A/s
PSW-720M160A	0.01A/s ~ 28.80A/s
PSW-1080M160A	0.01A/s ~ 43.20A/s
PSW-360M250A	0.001A/s ~ 9.000A/s
PSW-720M250A	0.01A/s ~ 18.00A/s
PSW-1080M250A	0.01A/s ~ 27.00A/s
PSW-360H800A	0.001A/s ~ 2.880A/s
PSW-720H800A	0.001A/s ~ 5.760A/s
PSW-1080H800A	0.001A/s ~ 8.640A/s

- Press the Function key again to exit the configuration settings.  
The function key light will turn off.
- Use the Voltage knob to set the current limit (crossover point).
- Use the Current knob to set the voltage.

Function



Voltage ①



Current ①



Note

Notice the Set key becomes illuminated when setting the current or voltage. If the Voltage or Current knobs are unresponsive, press the Set key first.

- Press the Output key.  
The Output key becomes illuminated.

Output

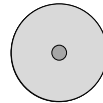

The display indicator's CC display and power bar will light up.

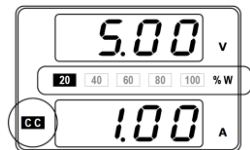





Note

When the output is turned on, the display becomes the output value. When the Set key is pressed, the display will show the set value.

For more information on the Normal Function Settings (F-00 ~ F-61, F-88~F-89) refer to page 66.

### 2.2.4. Set to CP Mode

This product can operate in constant power (CP) mode within the rated power. This allows the output of this product to operate at the set power value.

Before setting this product CP mode, please ensure the following:

The output is off.

The load is connected.

#### steps Step instructions

- 1 Press the Set key twice to display the constant power value.

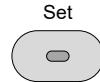
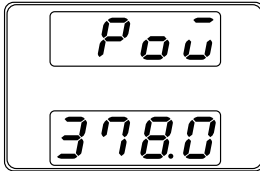

- 2 Use the current knob to set the constant power value.  
While setting the constant power value, the Set key is flashing.

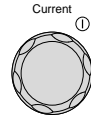

Model	Setting range / Setting resolution
360W	0.1W~378.0W / 0.1W
720W	0.1W~756.0W / 0.1W
1080W	1W~1134W / 1W

- 3 Press the Voltage knob to determine.  
When the settings are confirmed, "ConF" will be displayed.

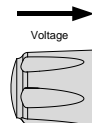



The constant power value is not initialized even when initializing with F-88 or using the \*RST command.

Operation may become unstable if the constant power value is less than 10% of the rated power or the current output value is less than 10% of the rated current.

### 2.2.5. Display Modes

This product can display output in three different modes: voltage and current, voltage and power, or current and power.

steps	Step instructions
1	Press the PWR DSPL key. The PWR DSPL key lights up.
2	The display changes to voltage and power (V/W).
3	To switch between displaying A/W and V/W, simply press the corresponding Voltage or Current knob. For example: when in A/W mode, press the Voltage knob to display V/W. Conversely when in V/W mode, press the Current knob to display A/W.

PWR DSPL

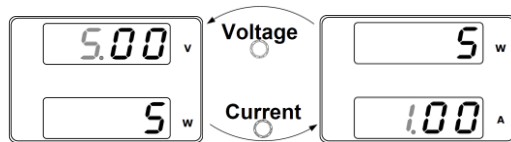

When V/W is displayed, the Voltage knob can still be used to change the voltage level.

When A/W is displayed, the Current knob can still be used to change the current level.

- Press the PWR DSPL key again to return to normal display mode.  
The PWR DSPL light will turn off.

PWR DSPL



### 2.2.6. Panel Lock

The panel lock feature prevents settings from being changed accidentally. When activated, the Lock/Local key will become illuminated and all keys and knobs except the Lock/Local key and Output key will be disabled.

When this product is remotely controlled via the USB/LAN interface, the panel lock is automatically enabled.

Activate the panel lock

Press the Lock/Local key to activate the panel lock. The key will become illuminated.

Lock/Local



Disable the panel lock

Hold the Lock/Local key for ~3 seconds to disable the panel lock. The Lock/Local light turns off.

Lock/Local

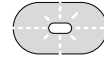

Note

When panel lock is enabled, the output key operation content changes depending on the setting status of basic function "F-19".

In F-19: 0 setting, output off operation is possible.

In F-19: 1 setting, output off/off operation is possible.

### 2.2.7. Remote Sense

Remote sense is used to compensate for the voltage drop seen across load cables due to the resistance inherent in the load cables. The remote sense terminals are connected to the load terminals to determine the voltage drop across the load cables.

The remote sense compensation voltage is maximum 0.6 volts for low voltage model and 1V maximum for high voltage model. The load cable should be selected with a voltage drop less than the compensation voltage.



Warning

Ensure the output is off before connecting any sense cables.

Use sense cables with a voltage rating exceeding the isolation voltage of this product.

Never connect sensing cables when the output is on. Electric shock or damage to this product could result.



Note

Disconnect the +S terminal and +V output terminal, and the -S terminal and -V output terminal so that this product does not become local sensing. For the constant voltage model, remove the metal plate (2 pieces), and for the high voltage model, remove the red and black wires from this product.

Please refer to pages [31](#) and [33](#) for how to wire the sensing cable to the  $\pm S$  terminal of this product.

1

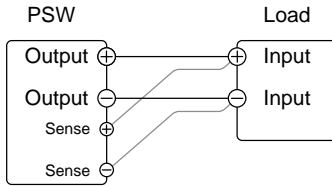

Independent operation connection

Connect the Sense+ terminal to the positive potential of the load. Connect the Sense- terminal to the negative potential of the load.

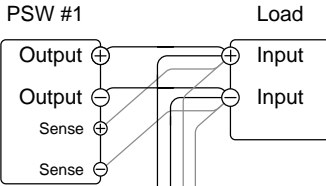

Parallel operation connection

Connect all Sense+ terminals to the positive potential of the load. Connect all Sense- terminals to the negative potential of the load.

Please refer to page 51 for control signal wiring and settings for PSW #1 and PSW #2.

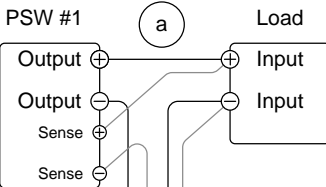
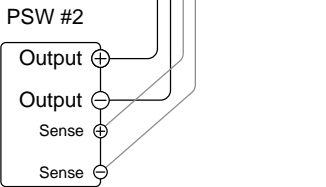

Series operation connection

a: Connect the Sense+ terminal of PSW #1 to the positive potential of the load.

b: Connect the Sense- terminal of PSW #1 to the Output+ terminal of PSW #2.

c: Connect the Sense+ terminal of PSW #2 to the Output+ terminal of PSW #2.

d: Connect the Sense- terminal of PSW #2 to negative potential.

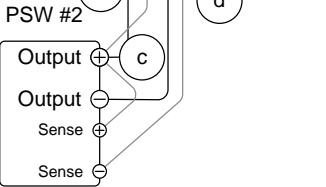

Please refer to page 56 for control signal wiring and settings for PSW #1 and PSW #2.

2 Operate this product as normal. Refer to the Basic Operation chapter for details (page 41).

Wire Shielding and Load line impedance

To help to minimize the oscillation due to the inductance and capacitance of the load cables, use an electrolytic capacitor in parallel with the load terminals.

To minimize the effect of load line impedance, use twisted wire pairing.

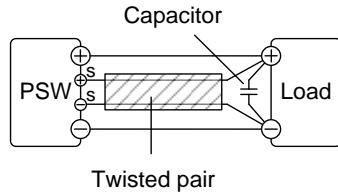

### 2.3. One-control parallel operation

This section describes the basic operations required to operate the power supply in parallel. Operating this product in parallel increases the total power output of the power supply units.

The number of the power supplies that can be connected in parallel depends on the model and the mode.

Parallel operation: 3 units maximum

To use this product in parallel, units must be used in a Master-Slave configuration. In the master-slave configuration a “master” power supply controls any other connected “slave” power supplies.

#### 2.3.1. Overview of one-control parallel operation

One-control parallel operation of this product is possible for up to three of the same models. There are some precautions and limitations when using this machine in parallel. Please read this overview carefully before starting parallel operation of this product.

Limitations	Description
Display	Only the master unit will display voltage and current. The current value is added and displayed.
OVP/ OCP (Overvoltage/overcurrent protection)	OVP/OCP detection is performed on the master unit. The OVP/OCP function of the slave unit is disabled. When the master unit detects OVP/OCP, the output is turned off, and at the same time, the output of the slave unit is also turned off.
Output monitor signal	The voltage monitor (VMON) and current monitor (IMON) can only be used on the master unit. The current monitor (IMON) signal represents the total current of all products connected in parallel.
Remote sensing function	Remote sensing function can be used. Refer to page 49 for more information.

Output voltage/current control by external signal input External voltage or external resistance can be input as external signal.  
Output voltage/current control using external signals is valid only for the master unit.

Internal resistance setting value When two units are connected in parallel, the value will be half (1/2) of the value set on the master unit.  
When 3 units are connected in parallel, the value will be 1/3 of the value set on the master unit.

Bleeder circuit control Bleeder circuit settings can only be made on the master unit. The slave unit 's bleeder circuit is always disabled (off).

Rated output during one-control parallel operation

Model name	Single unit	2 units	3 units
PSW-360L30A	30V, 36A	30V, 72A	30V, 108A
PSW-360L80A	80V, 13.5A	80V, 27A	80V, 40.5A
PSW-360M160A	160V, 7.2A	160V, 14.4A	160V, 21.6A
PSW-360M250A	250V, 4.5A	250V, 9.0A	250V, 13.5A
PSW-360H800A	800V, 1.44A	800V, 2.88A	800V, 4.32A
PSW-720L30A	30V, 72A	30V, 144A	30V, 216A
PSW-720L80A	80V, 27A	80V, 54A	80V, 81A
PSW-720M160A	160V, 14.4A	160V, 28.8A	160V, 43.2A
PSW-720M250A	250V, 9.0A	250V, 18.0A	250V, 27.0A
PSW-720H800A	800V, 2.88A	800V, 5.76A	800V, 8.64A
PSW-1080L30A	30V, 108A	30V, 216A	30V, 324A
PSW-1080L80A	80V, 40.5A	80V, 81A	80V, 121.5A
PSW-1080M160A	160V, 21.6A	160V, 43.2A	160V, 64.8A
PSW-1080M250A	250V, 13.5A	250V, 27.0A	250V, 40.5A
PSW-1080H800A	800V, 4.32A	800V, 8.64A	800V, 12.96A

### 2.3.2. Wiring for one-control parallel operation

When using this product in one-control parallel operation, wiring to connect this product to the load and control signal wiring between the master unit and slave units of this product are required.

steps	Step instructions
-------	-------------------

- 1 Turn off the power to all this product.
- 2 Connect the master and slave units to the load.

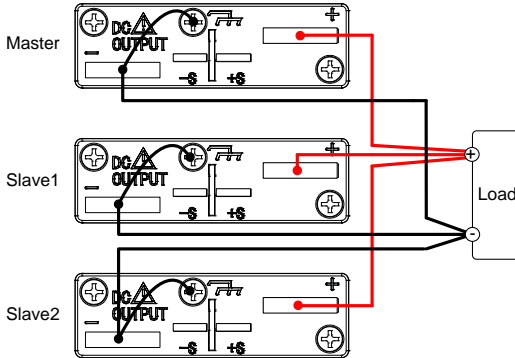

As a countermeasure against oscillation of the power supply output, it is recommended that the load wire be twisted.

The figure shows a low voltage model master unit and slave unit (2 units) connected to a load. Additionally, in the diagram above, the output of this product is negatively grounded (the negative output terminal and the case are connected).



Note

Please use a wire (load line) with sufficient capacity for the load line. Also, to equalize the output terminal potential of this product from the load, please use load wires of the same length and thickness as much as possible.

Refer to page 30 for load lines.

- 3 Attach the output terminal cover. Refer to page 32, 36
- 4 Wire the control signals between the master and slave units. Control signals for one-control parallel operation are wired to the analog control connector. Refer to page 106 for analog control connectors.

### Control signal wiring between master unit and slave unit (1 unit)

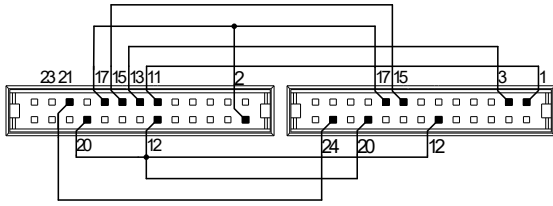

Master unit		Slave Unit 1		
11	I MON	---	1	CURRENT SHARE
21	OUTPUT ON STATUS	---	24	OUT ON/OFF CONT
20	ALM STATUS	---	12	SHUTDOWN
17	STATUS OOM	---	17	STATUS COM
15	FEEDBACK	---	15	FEEDBACK
13	CURRENT_SUM_1	---	3	CURRENT SUM OUT
12	SHUTDOWN	---	20	ALM STATUS
2	D.COM			

The above wiring can be done using the optional product PSW-006.

### Control signal wiring for master unit and slave units (2 units)

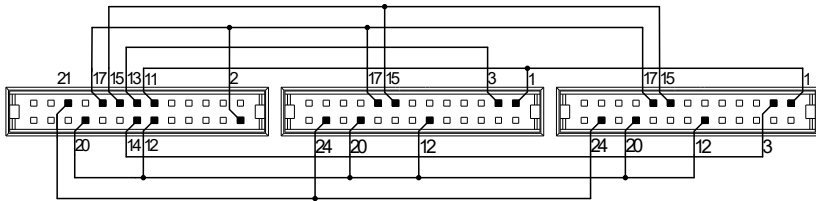

Master unit		Slave Unit 1		Slave Unit 2			
11	I MON	---	1	CURRENT SHARE	---	1	CURRENT SHARE
21	OUTPUT ON STATUS	---	24	OUT ON/OFF CONT	---	24	OUT ON/OFF CONT
20	ALM STATUS	---	12	SHUTDOWN	---	12	SHUTDOWN
17	STATUS COM	---	17	STATUS COM	---	17	STATUS OOM
15	FEEDBACK	---	15	FEEDBACK	---	15	FEEDBACK
14	CURRENT_SUM_2	---	---	---	---	3	CURRENT SUM OUT
13	CURRENT_SUM_1	---	3	CURRENT SUM OUT	---	---	---
12	SHUTDOWN	---	20	ALM STATUS	---	20	ALM STATUS
2	D.COM						

The above wiring can be done using the optional product PSW-007.



### 2.3.3. Settings and checking for one-control parallel operation

When using this product in one-control parallel operation, set the master and slave units for this product.

This product allows one-control parallel operation with a configuration of only the same model.

steps	Step instructions
-------	-------------------

- |   |   |
|---|---|
| 1 | From the power off state of this product, turn it on while pressing the Function key. |
|---|---|

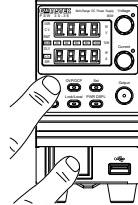

- |   |  |
|---|--|
| 2 | "F-90" will appear at the top of the display, and the F-90 configuration settings will appear at the bottom. |
|---|--|

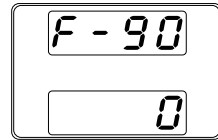

- |   |   |
|---|---|
| 3 | Rotate the voltage knob and set it to "F-93". |
|---|---|



- |   |  |
|---|--|
| 4 | Rotate the current knob to set the parameters for the selected F-93 setting. Depending on the set parameters, this device becomes a master unit or a slave unit. |
|---|--|

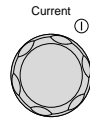

- F93: 1 Master unit: When there is one slave unit.  
 F93: 2 Master unit: When there are 2 slave units  
 F93: 3 Slave unit



Caution

Be sure to set only one master unit. Do not set multiple master units.

In addition, set all devices other than the master unit to slave units.

- |   |  |
|---|--|
| 5 | Press the voltage knob to confirm the configuration setting. When confirmed, "ConF" will be displayed. |
|---|--|



- 6 Turn off the power to this product and check that the various wiring between the master and slave units is properly connected. Refer to page 53.
- 7 Turn on the power of the master and slave units. The slave units will display "- - - -".

Master unit



Slave unit

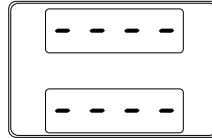

- 8 The master unit can perform various setting operations in one-control parallel operation. The operation method for the master unit is the same as for a standalone unit. Refer to page 41.
- 9 Press the Output key to turn on the output.

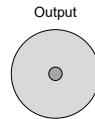

Note

In one-control parallel operation, only the master unit can be operated. On the slave units, only the Function key can be used to check the settings.

## 2.4. One-control series operation

This section describes the basic operations required to operate the power supply in series. Operating this product in series, the total output voltage of the power supplies can be increased.

The number of the power supplies that can be connected in series depends on the model and the mode.

Series operation: 2 units maximum (30V, 80V and 160V models only.)



CAUTION

250V and 800V models do not support series operation.

To use this product in series, units must be used in a Master-Slave configuration. In the master-slave configuration a “master” power supply controls any other connected “slave” power supplies.

### 2.4.1. Overview of one-control series operation

One-control series operation of this product is possible for up to two of the same models. There are some precautions and limitations when using this

product in series. Please read this overview carefully before beginning series operation of this product.

Limitations	Description
Display	Only the master unit displays the current value. The voltage value is displayed on both the master and slave units. For the voltage value, add the voltages of the master and slave units.
OVP/ OCP (Overvoltage/overcurrent protection)	OVP/OCP detection is performed on the master unit. The OVP/OCP function of the slave unit is disabled. When the master unit detects OVP/OCP, the output is turned off, and at the same time, the output of the slave unit is also turned off.
Output monitor signal	The voltage monitor (VMON) and current monitor (IMON) can only be used on the master unit. The voltage monitor (VMON) signal represents the total voltage of all products connected in series.
Remote sensing function	Remote sensing function can be used. Refer to page 49 for more information.
Output voltage/current control by external signal input	External voltage or external resistance can be input as external signal. Output voltage/current control using external signals is valid only for the master unit.
Slew rate	The current slew rate operates at the set value speed from the master unit. The voltage slew rate operates at twice the speed set from the master unit.
Internal resistance setting value	This will be twice the value set on the master unit.
Bleeder circuit control	Bleeder circuit settings can only be made on the master unit. The slave unit bleeder circuit is always enabled (on).

Rated output during one-control series operation

Model name	Single unit	2 units
PSW-360L30A	30V, 36A	60V, 36A
PSW-360L80A	80V, 13.5A	160V, 13.5A
PSW-360M160A	160V, 7.2A	320V, 7.2A
PSW-720L30A	30V, 72A	60V, 72A
PSW-720L80A	80V, 27A	160V, 27A

PSW-720M160A	160V, 14.4A	320V, 14.4A
PSW-1080L30A	30V, 108A	60V, 108A
PSW-1080L80A	80V, 40.5A	160V, 40.5A
PSW-1080M160A	160V, 21.6A	320V, 21.6A

### 2.4.2. Wiring for one-control series operation

When using this product in one-control series operation, wiring to connect this product to the load and control signal wiring between the master unit and slave units of this product are required.

steps	Step instructions
-------	-------------------

- 1 Turn off the power to all this product.
- 2 Connect the master and slave units to the load.

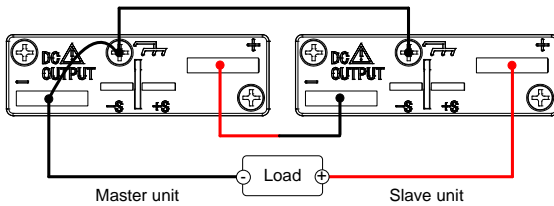

As a countermeasure against oscillation of the power supply output, it is recommended that the load wire be twisted.

The figure shows a low voltage model master unit and slave unit (2 units) connected to a load. Additionally, in the diagram above, the output of this product is negatively grounded (the negative output terminal and the case are connected).



Note

Please use a wire (load line) with sufficient capacity for the load line.

Refer to page 30 for load lines.

- 3 Attach the output terminal cover. Refer to page 32, 36
- 4 Wire the control signals between the master and slave units.  
Control signals for one-control parallel operation are wired to the analog control connector. Refer to page 106 for analog control connectors.

## Control signal wiring between master unit and slave unit (1 unit)

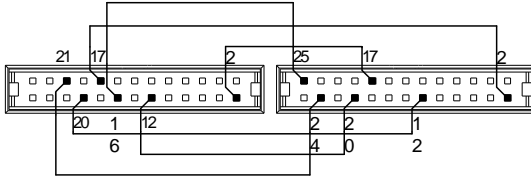

Master		Slave	
16	A COM	25	SER SLV IN
21	OUTPUT ON STATUS	24	OUT OFF/ON CONT
20	ALM STATUS	12	SHUTDOWN
17	STATUS COM	2	D COM
12	SHUTDOWN	20	ALM STATUS
2	D COM	17	STATUS COM

The above wiring can be done using the optional product PSW-005.

### 2.4.3. Settings and checking for one-control series operation

When using this product in one-control series operation, set the master and slave units for this product.

This product allows one-control parallel operation with a configuration of only the same model.

#### steps Step instructions

- 1 From the power off state of this product, turn it on while pressing the Function key.

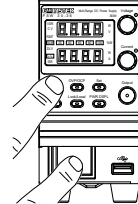

- 2 "F-90" will appear at the top of the display, and the F-90 configuration settings will appear at the bottom.

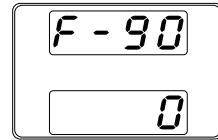

- 3 Rotate the voltage knob and set it to "F-93".



- 4 Rotate the current knob to set the parameters for the selected F-93 setting. Depending on the set parameters, this device becomes a master unit or a slave unit.



F93: 0 Master unit

F93: 4 Slave unit



Caution

Be sure to set only one master unit. Do not set multiple master units.

In addition, set all devices other than the master device as slave devices.

- 5 Press the voltage knob to confirm the configuration setting.

When confirmed, "ConF" will be displayed.

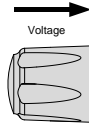

- 6 Turn off the power to this product and check that the various wiring between the master and slave units is properly connected.

Refer to page 53.

- 7 Turn on the power of the master and slave units. The slave units will display "- - - -".

Master unit



Slave unit

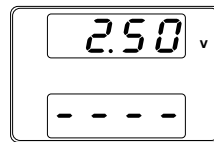

- 8 The master unit can perform various setting operations in one-control series operation. The operation method for the master unit is the same as for a standalone unit.

Refer to page 41.

- 9 Press the Output key to turn on the output.

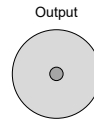

Note

In one-control series operation, only the master unit can be operated. On the slave units, only the Function key can be used to check the settings.

### 3. Function settings

The function settings of this product include various function settings, digital communication settings, external analog settings, power-on settings, calibration settings, etc.

External analog settings can only be set when the power switch is on.

Other settings can be configured while operating this product.

#### 3.1. Function settings list

When setting the function, there are the following restrictions.



Note

- \*1: Power on configuration settings only can be set during power up.
- \*2: Need to be used together with GUR-001.
- \*3: Need to be used together with GUR-001A.

##### 3.1.1. Normal Function

Item	Setting	Setting Range
Output ON delay time	F-01	0.00s ~ 99.99s
Output OFF delay time	F-02	0.00s ~ 99.99s
V-I mode slew rate	F-03	0: CV high speed priority 1: CC high speed priority 2: CV slew rate priority 3: CC slew rate priority
Rise voltage slew rate	F-04	The setting range varies depending on the models. Refer to page 66 for details.
Fall voltage slew rate	F-05	The setting range varies depending on the models. Refer to page 66 for details.
Rise current slew rate	F-06	The setting range varies depending on the models. Refer to page 66 for details.
Fall current slew rate	F-07	The setting range varies depending on the models. Refer to page 66 for details.
Internal resistance	F-08	The setting range varies depending on the models. Refer to page 68 for details.

Bleeder circuit control	F-09	0: OFF, 1: ON, 2: AUTO
Buzzer ON/OFF control	F-10	0: OFF, 1: ON
Measurement Average	F-17	0: Low, 1: Middle, 2: High
Output key operation (In panel lock active)	F-19	0: allow output off 1: allow output on/off

### 3.1.2. USB & GP-IB

Item	Setting	Setting Range
Front Panel USB State (Only for confirmation)	F-20	0: Absent 1: USB memory exists
Rear Panel USB State (Only for confirmation)	F-21	0: Not used 2: USB-CDC 3: GP-IB-USB adapter 5: RS-232C-USB adapter
Rear Panel USB state	F-22	0: Disable 1: USB Host 2: USB CDC (Auto detect speed) 3: USB CDC (Full speed)
GP-IB Address*2	F-23	0 ~ 30

### 3.1.3. LAN

Item	Setting	Setting Range
MAC Address-1 ~ 5	F-30~35	0x00 ~ 0xFF
LAN	F-36	0: Disable, 1: Enable
DHCP	F-37	0: Disable, 1: Enable
IP Address-1 ~ 4	F-39~42	0 ~ 255
Subnet Mask-1 ~ 4	F-43~46	0 ~ 255
Gateway-1 ~ 4	F-47~50	0 ~ 255
DNS address-1 ~ 4	F-51~54	0 ~ 255
Sockets active	F-57	0: Disable, 1: Enable
Web Server active	F-59	0: Disable, 1: Enable
Web password active	F-60	0: Disable, 1: Enable



Web setting password      F-61      0000~9999

### 3.1.4.    UART (RS-232C)

Settings for this item have \*3 restrictions.

Item	Setting	Setting Range
UART Baud Rate (Unit: bps)	F-71	0: 1200, 1: 2400, 2: 4800, 3: 9600 4: 19200, 5: 38400, 7: 115200
UART Data Bits (Unit: bit)	F-72	0: 7, 1: 8
UART Parity	F-73	0: None, 1: Odd, 2: Even
UART Stop Bit (Unit: bit)	F-74	0: 1, 1: 2

### 3.1.5.    Cooling fan stop function

Please refer to page [78](#) for how to set this function.

Item	Setting	Setting Range
Enabling/disabling setting of fan stop function	F-80	0: Fan stop function disabled state 1: Execute one action 3: Executing automatic actions
Fan stop time setting	F-81	1s ~ 120s

### 3.1.6.    Logging function

Please refer to page [80](#) for how to set this function.

Item	Setting	Setting Range
Starting and stopping the logging function	F-82	0: Stop 1: Start (USB memory) 2: Start (digital communication)
Logging time interval settings	F-83	0.1s ~ 999.9s
Logging data storage folder select	F-84	0000 ~ 9999

### 3.1.7.    Set value digit fixed function

Please refer to page [91](#) for how to set this function.

Item	Setting	Setting Range
Voltage set value fixed	F-85	0: Set digit operation disabled 1: Set digit operation enabled



Voltage settings	F-90	0: Panel control (local) 1: External voltage control 2: External resistance control 1 (Ext-R $\searrow$ 10k $\Omega$ = V ratings) 3: External resistance control 2 (Ext-R $\triangleright$ 10k $\Omega$ = 0V)
Current settings	F-91	0: Panel control (local) 1: External voltage control 2: External resistance control 1 (Ext-R $\searrow$ 10k $\Omega$ = I ratings) 3: External resistance control 2 (Ext-R $\triangleright$ 10k $\Omega$ = 0A)
Power-ON Output	F-92	0: OFF at startup 1: ON at startup T001 ~ T010: Run test script TXX at start up
External Out Logic	F-94	0: High ON, 1: Low ON
Power Switch trip*1	F-95	0: Enable, 1: Disable (Output off only)



Note

The power switch of this product is not a trip type switch. Enabling the F-95 will not turn off the power switch.

### 3.1.11. Calibration

Item	Setting	Setting Range
Calibration	F-00	0000 ~ 9999



Note

The settings for this item are not public.

## 3.2. Normal Function Settings

### 3.2.1. Output ON/OFF Delay Time

Delays turning the output on or off for the specified amount of time.

Item	Setting	Setting Range
Output ON Delay Time	F-01	0.00s ~ 99.99s
Output OFF Delay Time	F-02	0.00s ~ 99.99s

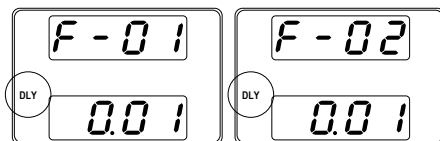

The “DLY” indicator will light when the Delay time is not 0.



Note

The Output ON/OFF Delay Time setting has a maximum deviation (error) of 20ms.

When the voltage setting or current setting is set to external control, the output on/off delay time setting will be disabled.

### 3.2.2. V-I mode slew rate setting

Sets High Speed Priority or Slew Rate Priority for CV or CC mode. The voltage or current slew rate can only be edited if CC/CV Slew Rate Priority is selected.

Item	Setting	Setting Range
V-I mode slew rate setting	F-03	0: CV high speed priority 1: CC high speed priority 2: CV slew rate priority 3: CC slew rate priority

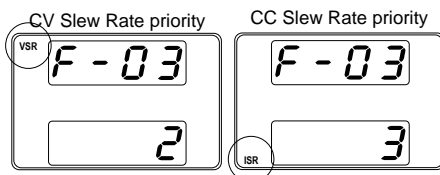

The VSR indicator will be lit for CV Slew Rate Priority and the ISR indicator will be lit for CC Slew Rate Priority.

The voltage slew rate can be set when the V-I mode slew rate is set to “CV slew rate priority” (F-03: 2).

Item	Setting	Voltage models	Setting Range
Rising voltage slew rate	F-04	30V	0.01V/s ~ 60.00V/s
		80	0.1V/s ~ 160.0V/s
		160	0.1V/s ~ 320.0V/s
		250	0.1V/s ~ 500.0V/s
		800	1V/s ~ 1600V/s
Falling voltage slew rate	F-05	30V	0.01V/s ~ 60.00V/s
		80	0.1V/s ~ 160.0V/s
		160	0.1V/s ~ 320.0V/s
		250	0.1V/s ~ 500.0V/s
		800	1V/s ~ 1600V/s

The current slew rate can be set when the V-I mode slew rate is set to “CC slew rate priority” (F-03: 3).

Item	Setting	Models	Setting Range
Rising current slew rate	F-06	PSW-360L30A	0.01A/s ~ 72.00A/s
		PSW-720L30A	0.1A/s ~ 144.0A/s
		PSW-1080L30A	0.1A/s ~ 216.0A/s
		PSW-360L80A	0.01A/s ~ 27.00A/s
		PSW-720L80A	0.01A/s ~ 54.00A/s
		PSW-1080L80A	0.01A/s ~ 81.00A/s
		PSW-360M160A	0.01A/s ~ 14.40A/s
		PSW-720M160A	0.01A/s ~ 28.80A/s
		PSW-1080M160A	0.01A/s ~ 43.20A/s
		PSW-360M250A	0.001A/s ~ 9.000A/s
		PSW-720M250A	0.01A/s ~ 18.00A/s
		PSW-1080M250A	0.01A/s ~ 27.00A/s
		PSW-360H800A	0.001A/s ~ 2.880A/s
		PSW-720H800A	0.001A/s ~ 5.760A/s
PSW-1080H800A	0.001A/s ~ 8.640A/s		
Falling current slew rate	F-07	PSW-360L30A	0.01A/s ~ 72.00A/s
		PSW-720L30A	0.1A/s ~ 144.0A/s

PSW-1080L30A	0.1A/s ~ 216.0A/s
PSW-360L80A	0.01A/s ~ 27.00A/s
PSW-720L80A	0.01A/s ~ 54.00A/s
PSW-1080L80A	0.01A/s ~ 81.00A/s
PSW-360M160A	0.01A/s ~ 14.40A/s
PSW-720M160A	0.01A/s ~ 28.80A/s
PSW-1080M160A	0.01A/s ~ 43.20A/s
PSW-360M250A	0.001A/s ~ 9.000A/s
PSW-720M250A	0.01A/s ~ 18.00A/s
PSW-1080M250A	0.01A/s ~ 27.00A/s
PSW-360H800A	0.001A/s ~ 2.880A/s
PSW-720H800A	0.001A/s ~ 5.760A/s
PSW-1080H800A	0.001A/s ~ 8.640A/s

### 3.2.3. Internal resistance setting

Set the internal resistance of this product output.

Item	Setting	Power module	Setting Range
Internal resistance setting	F-08	PSW-360L30A	0.000Ω ~ 0.833Ω
		PSW-720L30A	0.000Ω ~ 0.417Ω
		PSW-1080L30A	0.000Ω ~ 0.278Ω
		PSW-360L80A	0.000Ω ~ 5.926Ω
		PSW-720L80A	0.000Ω ~ 2.963Ω
		PSW-1080L80A	0.000Ω ~ 1.975Ω
		PSW-360M160A	0.000Ω ~ 22.222Ω
		PSW-720M160A	0.000Ω ~ 11.111Ω
		PSW-1080M160A	0.000Ω ~ 7.407Ω
		PSW-360M250A	0.00Ω ~ 55.55Ω
		PSW-720M250A	0.00Ω ~ 27.77Ω
		PSW-1080M250A	0.00Ω ~ 18.51Ω
		PSW-360H800A	0.0Ω ~ 555.5Ω
		PSW-720H800A	0.0Ω ~ 277.8Ω
PSW-1080H800A	0.0Ω ~ 185.1Ω		

### 3.2.4. Bleeder circuit control

Bleeder circuit control turns the bleeder circuit ON/OFF. When set to AUTO, the bleeder circuit turns on when the output is on and turns off when the output or power is turned off. Refer to page 20 for usage details.

Item	Setting	Setting Range	Bleeder circuit setting		
			Output ON	Output OFF	Power OFF
Bleeder circuit control	F-09	0: OFF	OFF	OFF	OFF
		1: ON	ON	ON	ON
		2: AUTO	ON	OFF	OFF

### 3.2.5. Buzzer ON/OFF control

Turns the buzzer sound on/off. The buzzer sound is generated when an alarm occurs and when the panel is operated.

Buzzer ON/OFF control can only be set from CH1.

Item	Setting	Setting Range
Buzzer ON/OFF control*1	F-10	0: OFF 1: ON

### 3.2.6. Measurement Average Setting

Configure the averaging settings for measured values.

Item	Setting	Setting Range
Measurement Average Setting	F-17	0: Low 1: Middle 2: High

### 3.2.7. Output key operation settings

Set the operation of the Output key when the panel is locked.

Item	Setting	Setting Range
Output key operation settings	F-19	0: allow output off 1: allow output on/off

### 3.3. USB/GPIB/UART/LAN Settings

#### 3.3.1. USB setting

Displays the usage status of the front and rear panel USB A ports and configures the rear panel USB.

Front Panel USB State	Setting	Setting Range
Displays the front panel USB-A port state. (Only confirmation)	F-20	0: Absent 1: USB memory exists
Rear Panel USB State	Setting	Setting Range
Displays the rear panel USB-B port state. (Only for confirmation)	F-21	0: Not used 2: USB-CDC 3: GPIB-USB adapter 5: RS-232C adapter
Rear Panel USB Mode	Setting	Setting Range
Sets the rear panel USB mode.	F-22	0: Disable 1: USB Host 2: USB CDC (Auto detect speed) 3: USB CDC (Full speed)



Note

When there is an interference source in the operating environment, setting “F-22: 3” and lower the data transfer rate, can reduce the influence of the interference source.

#### 3.3.2. GP-IB Address setting

Sets the GP-IB address.

Item	Setting	Setting Range
GP-IB Address	F-23	0 ~ 30

#### 3.3.3. UART communication setting

Sets the UART (RS-232C) communication settings. Settings can be made when GUR-001B is connected to this product.

UART Baud Rate	Setting	Setting Range
Set baud rate (Unit: bps)	F-71	0: 1200 1: 2400 2: 4800



- 3: 9600
- 4: 19200
- 5: 38400
- 6: 57600
- 7: 115200

UART Data Bits	Setting	Setting Range
Set data bits (Unit: bit)	F-72	0: 7 1: 8
UART Parity	Setting	Setting Range
Set parity	F-73	0: None 1: Odd 2: Even
UART Stop Bit	Setting	Setting Range
Set stop bit (Unit: bit)	F-74	0: 1 1: 2

### 3.3.4. LAN Settings

Sets the LAN communication settings.

Confirm MAC Address	Setting	Setting Range
MAC Address-1	F-30	0x00 ~ 0xFF
MAC Address-2	F-31	0x00 ~ 0xFF
MAC Address-3	F-32	0x00 ~ 0xFF
MAC Address-4	F-33	0x00 ~ 0xFF
MAC Address-5	F-34	0x00 ~ 0xFF
MAC Address-6	F-35	0x00 ~ 0xFF
Can only be checked, cannot be configured.		
Turns Ethernet on or off	Setting	Setting Range
LAN	F-36	0: Disable 1: Enable
DHCP	F-37	0: Disable 1: Enable
Sets the IP address	Setting	Setting Range
IP Address-1	F-39	0 ~ 255

IP Address-2	F-40	0 ~ 255
IP Address-3	F-41	0 ~ 255
IP Address-4	F-42	0 ~ 255

Set arbitrary values for IP addresses-1~4.

Sets the subnet mask	Setting	Setting Range
Subnet Mask-1	F-43	0 ~ 255
Subnet Mask-2	F-44	0 ~ 255
Subnet Mask-3	F-45	0 ~ 255
Subnet Mask-4	F-46	0 ~ 255

Set arbitrary values for Subnet Mask-1~4.

Sets the gateway	Setting	Setting Range
Gateway-1	F-47	0 ~ 255
Gateway-2	F-48	0 ~ 255
Gateway-3	F-49	0 ~ 255
Gateway-4	F-50	0 ~ 255

Set arbitrary values for Gateway-1~4.

Sets the DNS address	Setting	Setting Range
DNS address-1	F-51	0 ~ 255
DNS address-2	F-52	0 ~ 255
DNS address-3	F-53	0 ~ 255
DNS address-4	F-54	0 ~ 255

Set arbitrary values for DNS address-1~4.

Web socket connection settings.	Setting	Setting Range
Sockets active	F-57	0: Disable 1: Enable

Web server control settings.	Setting	Setting Range
Socket connection status	F-59	0: Disable 1: Enable

Turns a web password on/off.	Setting	Setting Range
------------------------------	---------	---------------

Web password active	F-60	0: Disable 1: Enable
<b>Sets the Web password</b>	<b>Setting</b>	<b>Setting Range</b>
Web password	F-61	0000~9999

### 3.4. System Settings

#### 3.4.1. Factory Set Value

Returns this product to the factory default settings. Refer to page [136](#) for a list of the default settings.

Item	Setting	Setting Range
Sets factory value	F-88	0: No effect 1: Return to factory settings 2: All channels return to factory settings

#### 3.4.2. Show Version

Displays this product version number, build date, keyboard version, analog-control version, kernel build, test command version and test command build date.

Can only be checked, cannot be configured.

Item	Setting	Range
Show Version	F-89	0, 1: Firmware version number 2, 3: Firmware build: Year 4, 5: Firmware build: Month - Day 6, 7: Keyboard CPLD version number 8, 9: Analog control CPLD version number A: Control Board version number B: Reserved C, D: Kernel build: Year E, F: Kernel build: Month - Day G, H: Test Command Version number I, J: Test Command build: Year K, L: Test Command build: Month - Day

### 3.5. Function settings at power-on

Power on configuration settings only can be set during power up.

#### 3.5.1. Voltage setting Control

Set voltage setting control using either panel control or external voltage/resistance control. For external voltage control, refer to page [109](#) (External Voltage Control of Voltage Output) and page [112](#) (External Resistance Control of Voltage Output).

Item	Setting	Setting Range
Voltage settings	F-90	0: Panel control (local) 1: External voltage control 2: External resistance control 1 (Ext-R $\searrow$ 10k $\Omega$ = V ratings) 3: External resistance control 2 (Ext-R $\swarrow$ 10k $\Omega$ = 0V)

#### 3.5.2. Current setting Control

Set current setting control using either panel control or external voltage/resistance control. For details on external voltage control, refer to page [110](#) (External Voltage Control of Current Output) and page [113](#) (External Resistance Control of Current Output).

Item	Setting	Setting Range
Current settings	F-91	0: Panel control (local) 1: External voltage control 2: External resistance control 1 (Ext-R $\searrow$ 10k $\Omega$ = I ratings) 3: External resistance control 2 (Ext-R $\swarrow$ 10k $\Omega$ = 0A)

### 3.5.3. Power-ON Output

Configures this product to do one of the following at startup.

Item	Setting	Setting Range
Power-ON Output	F-92	0: OFF at startup 1: ON at startup T001 ~ T010: Run test script TXX at start up

### 3.5.4. External Out Logic

Set the logic for turning on the output using an external control.

The output is turned on by either active high (open) or active low (short).

Item	Setting	Setting Range
External Out Logic	F-94	0: Active high 1: Active low

### 3.5.5. Power Switch trip

Item	Setting	Setting Range
Power Switch trip	F-95	0: Enable 1: Disable



Note

The power switch of this product is not a trip type switch. Even if this setting is enabled, the power switch will not turn off.

## 3.6. Calibration

The calibration password is used to access the local mode calibration or other special functions. The password used determines which function is accessed.

The settings for this item are not public.

Item	Setting	Setting Range
Calibration	F-00	0000 ~ 9999





## 3.7. Setting Normal Function Settings

The normal function settings (F-01 ~ F-61, F88 ~ F89, F130 ~ F132) can be easily configured with the Function key.

Before operation, please check the following.

Ensure the load is not connected.

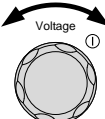
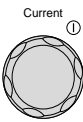
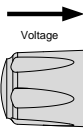
Ensure the output is off.

steps	Step instructions	
1	Press the Function key. The function key will light up.	Function 
2	The display will show F-01 on the top and the configuration setting for F-01 on the bottom.	
3	Rotate the Voltage knob to change the F-XX setting. F-XX: F-00 ~ F-61, F-88 ~ F-89 and F130 ~ F132	
4	Use the Current knob to set the parameter for the chosen F-XX setting.	
5	Press the voltage knob to determine configuration settings. When the settings are confirmed, "ConF" will be displayed.	
6	Press the Function key again to exit the configuration settings. The Function key turns off.	Function 

### 3.8. Setting Power on Configuration Settings

Power-on configuration settings can only be set at power-on to prevent configuration settings from being changed inadvertently.

Before operation, please check the following.

Ensure the load is not connected.

Ensure the output is off.

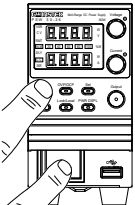
steps	Step instructions	
1	Hold the Function key whilst turning the power on.	

- 2 The display of all channel will show F-90 on the top and the configuration setting for F-90 on the bottom.

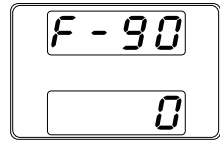

- 3 Rotate the Voltage knob to change the F-XX setting.  
F-XX: F-90~ F-95



Current



- 4 Use the Current knob to set the parameter for the chosen F setting.

- 5 Press the voltage knob to determine configuration settings.  
When the settings are confirmed, "ConF" will be displayed.



- 6 Turn the power off and then on again.

## 4. Special functions

### 4.1. Cooling fan stop function

This function temporarily stops the operation of the cooling fan. Use this when there is a problem with fan operation.



Continuous operation with the cooling fan stopped is not possible. After the cooling fan is stopped, the cooling fan stop function is disabled for the fan stop time. If the cooling fan stop function is disabled, “2” will be displayed on the current display.



**Caution** If the cooling fan remains stopped for a long time, it may cause a malfunction.  
Please use the minimum amount necessary.

#### 4.1.1. Fan stop time setting

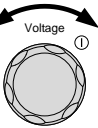
Before executing the fan stop function, set the fan stop time.

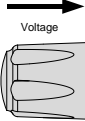
steps	Step instructions	
1	Press the Function key. The Function key will light up.	
2	Rotate the Voltage knob to change the F setting to F-81. F-81: Fan stop time setting	
3	Use the Current knob to set the F-81 setting. Setting Range: 1s ~ 120s	
4	Press the voltage knob to determine the fan stop time. When the settings are confirmed, “ConF” will be displayed.	
5	Press the Function key to finish setting the fan stop time. The Function key turns off.	



### 4.1.2. Executing the fan stop function

The fan stop function can be selected from two types of operation: Execute one action and executing automatic actions.

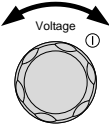
steps	Step instructions	
1	Press the Function key. The Function key will light up.	 <p>Function</p>
2	Rotate the Voltage knob to change the F setting to F-80. F-80: Enabling/disabling setting of fan stop function	 <p>Voltage</p>

 **Note** "0" is displayed at the bottom of the display. "0" means the fan stop function is disabled state.

#### Execute one action

- Turn the current knob and set the lower part of the display to "1".
- Press the voltage knob to execute the fan stop function.  
"ConF" (→"1") will be displayed at the bottom of the display and the fan will stop for the set time.
- When the set fan stop time has elapsed, the bottom of the display will display "1" → "2" and the fan will start operating.

 **Note** If "2" is displayed at the bottom of the display, the fan stop function cannot be executed. The fan stop function execution disabled time is the same time as the fan stop time.

- When the fan stop function execution disabled time has elapsed, the lower part of the display changes from "2" to "0". The fan stop function can be executed from step 3.

#### Executing automatic actions

- From step 2, turn the current knob and set the bottom of the display to "3".

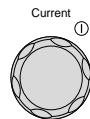

- 8 Press the voltage knob to execute the fan stop function.  
 "ConF" → "3" is displayed at the bottom of the display, and the fan stops and operates repeatedly at the set time interval.

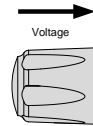

Note

If the fan stop function is executed automatically, the automatic execution will not stop even if finish setting the fan stop time.

## 4.2. Logging function

The logging function is a function that records and saves the output status (output voltage value, output current value, status) of this device at set time intervals (0.1sec to 999.9sec).

8000 pieces of logging data can be saved in the internal memory of the device. Logging data stored in this device can be output to a controller (PC, etc.) via an external USB memory or digital communication while the logging function is in operation.

If the logging data stored in this product's internal memory exceeds 8000 items, the data will be deleted. Please output the saved logging data before the saved logging data exceeds 8000 pieces.

### 4.2.1. Logging time interval settings

Set the logging time interval before starting the logging function.

steps	Step instructions	
1	Press the Function key. The Function key will light up.	
2	Rotate the Voltage knob to change the F setting to F-83. F-83: Logging time interval settings	
3	Use the Current knob to set the F-83 setting. Setting Range: 0.1s ~ 999.9s	

- 4 Press the voltage knob to determine the logging time interval.  
When the settings are confirmed, "ConF" will be displayed.

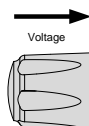

- 5 Press the Function key to finish setting the logging time interval.  
The Function key turns off.

 **Note** When outputting logging data via digital communication, you can use the logging time interval setting command (SENSe:DLOG:PERiod).

 **Caution** The logging time interval cannot be set while the logging function is in operation.

#### 4.2.2. Logging function operation: USB memory

this product can store up to 8000 pieces of logging data in its internal memory. While the logging function is in operation, logging data is output in units of 1000 to an external USB memory in CSV file format.

Additionally, when the logging function is stopped, the logging data (less than 1000 pieces) that has not been output to the USB memory will be output to the USB memory in CSV file format.

 **Caution** Before starting the logging function, ensure that the logging time interval is set. Refer to page 80.

#### steps Step instructions

##### Insert USB memory

- 1 Insert the USB memory into the USB-A slot on the front panel.

When the USB memory is recognized (after a few seconds), "MS (Mass Storage) on" will appear on the display.

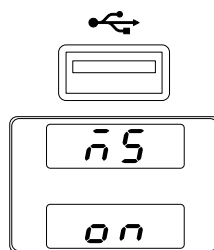

 **Note** Even while the logging function is operating, it is possible to remove/insert the USB memory as long as data is not being output to the USB memory.

 **Caution** If the USB memory is removed while logging data is being output to the USB memory, the logging data may be destroyed. Please use a USB memory with an access LED so that you can check the output operation to the USB memory.

## Logging data storage folder selection operation

- 2 Press the Function key.  
The Function key will light up.
- 3 Rotate the Voltage knob to change the F setting to F-84.  
F-84: Logging data storage folder select
- 4 Use the Current knob to set the F-84 setting.  
Setting Range: 0000 ~ 9999
- 5 Press the voltage knob to determine the logging data storage folder.  
When the settings are confirmed, "ConF" will be displayed.

Function



Current

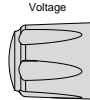

Note

Logging data will be output to the storage folder of the USB memory (the folder selected in step 2-5).



Note

When outputting logging data via digital communication, this data storage folder selection is disabled.



Caution

This operation cannot be performed while the logging function is in operation.

## Logging function start operation

- 6 Rotate the Voltage knob to change the F setting to F-82.  
F-82: Starting and stopping the logging function
- 7 Rotate the current knob and set it to "1".



Current



Note

When outputting logging data using digital communication, set "2".

- 8 Press the voltage knob.  
"ConF" will be displayed and the logging function will start.  
The voltage display blinks while the logging function is in operation.





Note

In step 8, press the Function key to turn off the key and complete the logging function settings. At this time, the logging function is still operating even if the logging function settings have been completed.

This product can be operated while the logging function is in operation (voltage display blinking).



Note

If 1000 pieces of logging data are saved in this product's internal memory while the USB memory is installed and the logging function is operating, the 1000 pieces of logging data will be output to the USB memory in CSV file format.



Note

After the power is turned on, the first logging data name output to the USB memory is "0000.csv". Each time logging data is output to the USB memory, the file name increases by one, up to a maximum of "9999.csv".



Caution

When outputting logging data from this product to a USB memory, if a file with the same name exists in the folder on the USB memory (the folder selected in step 2-5), it will be overwritten.



Caution

If the USB memory is not installed and the logging data exceeds 8000 in this product's internal memory, the oldest 1000 logging data stored in this product's internal memory will be deleted.

### Logging function stop operation

- 9 Press the Function key.  
The Function key will light up.
- 10 Rotate the Voltage knob to change the F setting to F-82.  
F-82: Starting and stopping the logging function
- 11 Rotate the current knob and set it to "0".
- 12 Press the voltage knob.  
"ConF" will be displayed and the logging function will stop.

Function



Current





Note

When the logging function stop, the logging data (less than 1000 pieces) saved in this product's internal memory that is not output to the USB memory will be output.



Caution

If the logging function is stopped without the USB memory installed, the logging data saved in this product's internal memory that is not output to the USB memory will be deleted.

#### 4.2.3. CSV file output to USB memory

Logging data saved to the USB memory using the logging function is saved in the logging data storage folder (0000 ~ 9999) of a folder in the USB memory.

Example of USB memory contents

```

└─ 20011361_000
   └─ 0000
      0000.csv

```

“20011361\_000” folder:

This folder is automatically created when logging data is output to a USB memory. The folder name is undefined and cannot be specified.

”0000” folder:

This is the folder where logging data is storage. This will be the folder name set in the logging data storage folder selection.

“0000.csv” file:

This is logging data. When the logging function starts after this product is turned on, the data will be stored sequentially starting from "0000.csv".



Caution

This product has no clock function. Therefore, the timestamp on a folder or file is not the date the folder or file was created or updated.

#### Logging data content

The following contents are saved in the logging data CSV file.

Sample Period: Logging time interval (seconds)

Number: Data number

Vmeas(V): Measured voltage value (V)

Imeas(A): Measured current value (A)

States(Hex): Device status during logging

Contents of States: Bit0=LSB, Bit31=MSB

Bit 0	Calibration mode	Bit 16	OVP
Bit 1	Locked state	Bit 17	OCP
Bit 2	(Unused)	Bit 18	(Unused)

Bit 3	Output OFF/ON	Bit 19	AC power OFF
Bit 4	Remote state	Bit 20	OTP
Bit 5	Waiting for trigger	Bit 21	WDOG
Bit 6	(Unused)	Bit 22	(Unused)
Bit 7	(Unused)	Bit 23	(Unused)
Bit 8	CV mode	Bit 24	Voltage limit
Bit 9	CP mode	Bit 25	Current limit
Bit 10	CC mode	Bit 26	(Unused)
Bit 11	Output ON delay	Bit 27	Shutdown
Bit 12	Output OFF delay	Bit 28	Power limit
Bit 13	(Unused)	Bit 29	(Unused)
Bit 14	TEST mode	Bit 30	UVP
Bit 15	(Unused)	Bit 31	(Unused)

When operating under CP mode, Bit 8 (CV mode) is also set at the same time as Bit 9.

Data example: The two types of data examples have the same content.

Data example: For Excel

	A	B	C	D
1	Sample Period : 1.0 sec			
2	Number	Vmeas(V)	Imeas(A)	State(Hex)
3	0	0	0	0x00000010
4	1	0	0	0x00000010
5	2	0	0	0x00000010
6	3	0	0	0x00000010
7	4	4.982	0.242	0x00000118
8	5	4.982	0.242	0x00000118
9	6	4.982	0.242	0x00000118
10	7	4.982	0.242	0x00000118
11	8	4.982	0.242	0x00000118
12	9	0	0	0x00000010
13	10	0	0	0x00000010
14	11	0	0	0x00000010
15	12	9.982	0.489	0x00000118
16	13	9.982	0.489	0x00000118
17	14	9.982	0.489	0x00000118
18	15	9.982	0.489	0x00000118
19	16	9.982	0.489	0x00000118

Data example: For CSV data

Sample Period : 1.0 sec

Number,Vmeas(V),Imeas(A),State(Hex)

0,0,0,0x00000010

1,0,0,0x00000010  
 2,0,0,0x00000010  
 3,0,0,0x00000010  
 4,4.982,0.242,0x00000118  
 5,4.982,0.242,0x00000118  
 6,4.982,0.242,0x00000118  
 7,4.982,0.242,0x00000118  
 8,4.982,0.242,0x00000118  
 9,0,0,0x00000010  
 10,0,0,0x00000010  
 11,0,0,0x00000010  
 12,9.982,0.489,0x00000118  
 13,9.982,0.489,0x00000118  
 14,9.982,0.489,0x00000118  
 15,9.982,0.489,0x00000118  
 16,9.982,0.489,0x00000118

#### 4.2.4. Logging function operation: digital communication

This product can store up to 8000 pieces of logging data in its internal memory. When the logging function is in operation, logging data is output to the controller via digital communication. To output logging data to the controller, use the logging data return request command (FETCh:DLOG?). The maximum number of logging data output is 1000 pieces/time, and it is output in IEEE-488.2 binary block format.



**Caution** Before starting the logging function, ensure that the logging time interval is set. Refer to page [80](#).

#### steps Step instructions

##### Digital communication method selection

- 1 Set the digital communication method used for logging data output. Refer to page [70](#), [122](#)

##### Logging function start operation

- 2 Send the logging function start command (SENSe:DLOG:STATe 2) from the controller to this product. Refer to programming manual



**Note** When outputting logging data to USB memory, send the "SENSe:DLOG:STATe 1" command.



- 3 The logging function starts when the logging function start command is sent to this product.

The voltage display blinks while the logging function is in operation.



Note

While the logging function is in operation (voltage display flashing), commands can be sent to this product and the device can be operated manually. Manual operation can be performed by placing this product in local mode.

#### Logging data output to controller

- 4 When the controller sends the logging data return request command (FETCh:DLOG?) to this product, the logging data is output to the controller. Refer to programming manual



Note

The maximum number of logging data output is 1000 pieces/time, and it is output in IEEE-488.2 binary block format.

Logging data output to the controller will be deleted from this product's internal memory.



Note

While the logging function is in operation, logging data can be output to the controller any number of times.



Caution

Logging data cannot be output to the controller while the logging function is stopped.



Caution

If the amount of logging data in the internal memory of this product exceeds 8000, the oldest 1000 logging data stored in the internal memory of this product will be deleted. Perform the logging data output operation before 8000 pieces of logging data are saved in the internal memory of this product.

#### Logging function stop operation

- 5 Send the logging function stop command (SENSe:DLOG:STATe 0) from the controller to this product. Refer to programming manual

- 6 When the logging function stop's command is sent to this product, the logging function stop.

The voltage display will change from blinking to lit.



Note

The logging function is stop by setting "F-82: 0" in this product local state.



Caution

When the logging function stop, the logging data saved in this product's internal memory will be deleted.

#### 4.2.5. Logging data output to controller

Logging data output to the controller is output in IEEE-488.2 binary block format (number of data: max. 1000 pieces/time). Make sure the controller is in a state where it can receive this data format.

When logging data is output multiple times while the logging function is in operation, please save and manage the data on the controller side.

##### Logging data content

The following contents are output with one logging data output. Data is output consecutively without being separated by spaces or ", ". "X" in the data content is the amount of data. One data amount (X=1) is one 2-digit hexadecimal value. If X=2, there will be two 2-digit hexadecimal numbers.

**<Start code: 1><Number digits in data count: 1><Data count: 8>**

**<Reserved: 2><Checksum: 4><Start number: 4>**

**<Sample period: 4><Number of log data: 4>**

**{Cell-0: 12} ... {Cell-999: 12}<End code: 1>**

{Cell-N} = <StateN: 4><VmeasN: 4><lmeasN: 4> (N: 0, ..., 999)

As a data example, in the case of "1 logging count, CV mode OUTPUT on, 24.988V, 0A", the following continuous data will be output.

**23383030303030303030303000000610200000000000060EA000001000000  
180100009C610000000000000A**

**<Start code: 1> Example data: 23**

It means the beginning of data. This is a fixed value, expressed as "#" in ASCII notation.

**<Number digits in data count: 1> Example data: 38**

This is the number of digits data when "Data count" is converted to a decimal number. In ASCII notation, it is "8". The number of digits in "Data count" will be 8 digits.

**<Data count: 8> Example data: 3030303030303330**

This is the amount of data between "Data count" and "End code".

In ASCII notation, it is "00000030". The total amount of data means 30 items (X=30).

**<Reserved: 2> Example data: 0000**

It's a reservation number and doesn't mean anything.

Fixed value data (X=2).

**<Checksum: 4> Example data: 61020000**

This is the sum of the data values between "Checksum" and "End code".

$00+\dots+60+EA+\dots+01+\dots+18+01+\dots+9C+61+\dots+00 = 00000261$

The data will be output starting from the lowest digit and will be

"61020000".

**<Start number: 4> Example data: 00000000**

The logging data output count data since the logging function started is output starting from the lowest digit.

When written as a decimal number, the number of times data is 0 to 1,999,999,999. After starting the logging function, the first logging data output count data will be "0". The number of times the logging data is output increases by one each time the logging data is output. If the number of logging data output exceeds "1,999,999,999" or if the logging function is "stopped → restarted", the output number data will return to "0".

"00000000" in the data example is "0", so it will be the first logging data output.

Other examples of output times

When the output count data is "12000000"

$$18(12h) \times 256^0 + 0(00h) \times 256^1 + 0(00h) \times 256^2 + 0(00h) \times 256^3 \\ = 18 + 0 + 0 + 0 = 18 = 19\text{th logging data output}$$

When the output count data is "FF933577"

$$255(\text{FFh}) \times 256^0 + 147(93h) \times 256^1 + 53(35h) \times 256^2 + 119(77h) \times 256^3 \\ = 255 + 37,632 + 3,473,408 + 1,996,488,704 = 1,999,999,999 \\ = 2,000,000,000\text{th logging data output}$$

**<Sample period: 4> Example data: 60EA0000**

Outputs the set logging time interval starting from the lower digits.

Unit: ms

The data example "60EA0000" has the following time.

$$96(60h) \times 256^0 + 234(\text{EAh}) \times 256^1 + 0(00h) \times 256^2 + 0(00h) \times 256^3 \\ = 96 + 59,904 + 0 + 0 = 60,000\text{ms} = 60\text{s}$$

**<Number of log data: 4> Example data: 01000000**

"Number of log data" is the number of pieces of logging data.

Outputs the number of "Cell-N" to be output starting from the lower digit.

Unit: pieces

The data example "01000000" has the following number.

$$1(01h) \times 256^0 + 0(00h) \times 256^1 + 0(00h) \times 256^2 + 0(00h) \times 256^3 \\ = 1 + 0 + 0 + 0 = 1 = 1 \text{ piece}$$

**{Cell-0: 12} ... {Cell-999: 12}** (N: 0, ..., 999)

**Example data: 180100009C61000000000000** (X=12)

"Cell-X" is measurement data. Outputs the measurement data stored in the main unit's internal memory in order from oldest to newest. The amount of measurement data for one item is 12 items (X=12).

**<StateN: 4><VmeasN: 4><lmeasN: 4>** (N: 0, ..., 999)

**Example data: 180100009C61000000000000**



### 4.3. Set value digit fixed function

This function enables or disables setting digit operation when setting voltage or current using the voltage or current knob on the front panel. This function can only be set using the front panel operation. There is no command to configure this feature.

#### 4.3.1. Setting method of setting digit

Enable or disable setting digit operation can be set to the lower 3 digits.

steps	Step instructions
-------	-------------------

- |   |  |
|---|--|
| 1 | Press the Function key.<br>The Function key will light up. |
|---|--|

Function



- |   |   |
|---|---|
| 2 | Turn the voltage knob to select "Voltage set value fixed" or "Current set value fixed". |
|---|---|



Set the top of the display to "F-85" or "F-86".

F-85: Voltage set value fixed

F-86: Current set value fixed



Note

The setting digit will be displayed as "X.X.X" at the bottom of the display. X is "0 or 1". "0" means that the set digit operation is disabled, and "1" means that the set digit operation is enabled.

- |   |  |
|---|--|
| 3 | Press the current knob and select the setting digit.<br>The setting digit (one "X" of the setting digit "X.X.X") is highlighted. |
|---|--|



- |   |  |
|---|--|
| 4 | Turn the current knob to set the digit.<br>0: Set digit operation disabled<br>1: Set digit operation enabled |
|---|--|

Current



- |   |   |
|---|---|
| 5 | Repeat steps 3 and 4 to set other digits. |
|---|---|

- |   |   |
|---|---|
| 6 | Press the voltage knob to determine whether setting digit operation is enabled or disabled. |
|---|---|



When the settings are confirmed, "ConF" will be displayed.

- |   |  |
|---|--|
| 6 | Press the Function key to finish this function setting.<br>The Function key turns off. |
|---|--|



Note

If "0.0.0" is set on F-85, voltage cannot be set during normal operation. Press the voltage knob and "MSG F-85" will be displayed.



Note

If "0.0.0" is set on F-86, current cannot be set during normal operation. Press the current knob and "MSG F-86" will be displayed.

#### 4.4. tUVP function

The tUVP (Tracking under voltage protection) function is a function that turns off the output of this product if the next measured output voltage value (approximately 20ms later) is lower than the set voltage value compared to the currently measured output voltage value.

##### 4.4.1. Setting method of the tUVP function

The tUVP function sets the following items.

Enable or disable this function: Set whether to enable or disable this function.

Delay time: Set the time for this function to become effective after the output is turned on.

Voltage drop value: Set the voltage drop value between two output voltage measurements.

steps	Step instructions
-------	-------------------

- |   |  |
|---|--|
| 1 | Press the Function key.<br>The Function key will light up. |
|---|--|

Function



##### Function enable/disable setting

- |   |  |
|---|--|
| 2 | Rotate the Voltage knob to change the F setting to F-A0.<br>F-A0: tUVP function enable/disable setting |
|---|--|



- |   |   |
|---|---|
| 3 | Rotate the current knob to set enable/disable of this function. |
|---|---|

Current



0: Disable

1: Enable, compare by instantaneous value voltage

2: Enable, compare by average value voltage



Note

When "F-A0: 2" is set, the measured value of output voltage will be the value set in measurement averaging (F-17).

- 4 Press the voltage knob to determine enabled or disabled.  
When the settings are confirmed, "ConF" will be displayed.

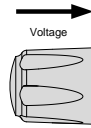

Delay time setting

- 5 Rotate the Voltage knob to change the F setting to F-A1.  
F-A1: tUVP function delay time setting

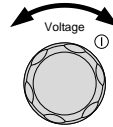

- 6 Rotate the current knob to delay time setting.  
Setting Range: 0.1s ~ 60.0s

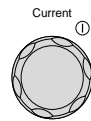

- 7 Press the voltage knob to determine delay time setting.  
When the settings are confirmed, "ConF" will be displayed.

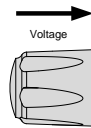

Voltage drops value setting

- 8 Rotate the Voltage knob to change the F setting to F-A2.  
F-A2: tUVP function voltage drops value setting

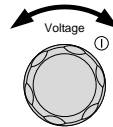

- 9 Rotate the current knob to delay time setting.  
Setting Range: 0.01 or 0.1V ~ Rated voltage

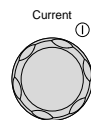

Note

The setting range varies depending on the minimum digit of the power module voltage display. Models with a minimum digit of 10mV will have a value of ``0.01," and models with a minimum digit of 100mV will have a value of ``0.1."

- 10 Press the voltage knob to determine voltage drops value.  
When the settings are confirmed, "ConF" will be displayed.

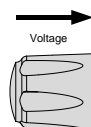

- 11 Press the Function key to finish this function setting.  
The Function key turns off.

#### 4.4.2. Output on/off operation when UVP function is enabled

If the tUVP function is enabled and the output voltage drops when the output of this product is on, the output of this product will be turned off and "UVP" will be displayed on the display.

steps	Step instructions
-------	-------------------

- |   |  |
|---|--|
| 1 | Set the tUVP function to enabled. Press the output key to turn on the output of this product.<br>The output key will light up. |
|---|--|

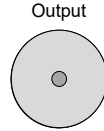

Note

After the output is turned on, the tUVP function is disabled for the set delay time.

- |   |  |
|---|--|
| 2 | If a voltage drop that exceeds the set voltage drop value occurs between two output voltage measurements, this product output will turn off and "UVP" will be displayed at the top of the display. |
|---|--|



Note

If "UVP" is displayed on the display, this product cannot be operated.



Note

When tUVP operates, the output voltage of this product will drop at the fastest slew rate time. Additionally, if tUVP operates during test script operation, the output voltage of this product will drop at the set slew rate time.

- |   |   |
|---|---|
| 3 | To enable operation of this product from step 2, press the OVP/OCP key for 3 seconds or more. |
|---|---|





## 4.5. Test mode function

This section describes how to use the Test mode function to run, load and save test mode for automated testing.

The test mode feature is useful for automatically running large numbers of tests. The test mode function can store ten test mode in memory.

In the test mode function, the settings (voltage, current, etc.) are updated according to the set time.

Each test mode data file can be created in CSV format and read from a USB memory.

USB memory formatted in FAT format can be used. Please use the USB memory after deleting all files other than the test mode data file.

### 4.5.1. Test mode File Format

The test mode data consists of a pair of CSV format files (tXXX.csv) and TST format files (tXXX.tst). The file name is "tXXX". "XXX" indicates file number 001-010.

The test mode function runs data from a CSV file. Create a test mode data file by editing the CSV file.

CSV format files (tXXX.csv) and TST format files (tXXX.tst) can be downloaded from our website.

### 4.5.2. Test mode setting items

Test Run	<p>Runs the selected test mode data from the internal memory of this product. Test mode must be loaded into the product's internal memory before they can be run.</p> <p>Refer to the test function "Test Load", below.</p> <p>Execute and stop the test mode function by operating the Output key.</p> <p>Refer to page 98 for operating instructions.</p> <p>T-01                      1~10</p>
Test Load	<p>Load the test mode data from the USB memory into the internal memory of this product.</p> <p>Refer to page 97 for operating instructions.</p> <p>T-02                      1~10 (USB → PSW)</p>
Test Export	<p>Exports the specified test mode data in this product's internal memory to a USB memory.</p> <p>Refer to page 100 for operating instructions.</p> <p>T-03                      1~10 (PSW → USB)</p>

- Test Remove Delete the selected test mode data from the internal memory of this product.  
 Refer to page 101 for operating instructions.  
 T-04 1~10, ALL
- Test Memory Displays the available internal memory capacity of this product in kilobytes (1024 bytes).  
 Refer to page 101 for operating instructions.  
 T-05 Max: 1852 k bytes

### 4.5.3. Setting the Test mode Settings

Press the Test key and configure the test mode items settings (T-01 to T-05).

steps	Step instructions
-------	-------------------

- |   |   |   |
|---|---|---|
| 1 | Press the Test key.<br>The Test key will light up.  |  |
| 2 | Test mode setting items (Test Setting) are displayed at the top of the display. In the explanatory diagram, it is "T-01 (Test Run)".<br>The product's internal memory number is displayed on the bottom right side of the display. In the explanatory diagram, the memory number is "1".<br>If there is no test mode data in this product's internal memory number, "n" will be displayed at the bottom left of the display. This means that the script is not present. |   |

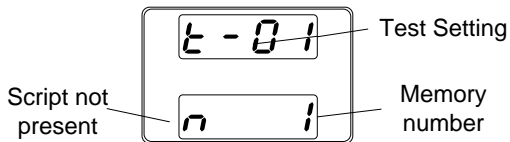

If there is test mode data in this product's internal memory number, "y" will be displayed at the bottom left of the display. This means that the script is present.

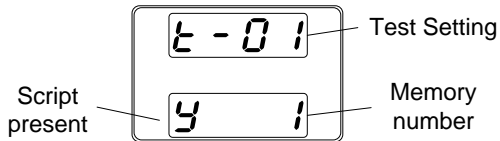

- 3 Rotate the Voltage knob to change the test mode setting items (Test setting).

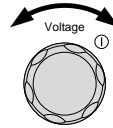

T-01: Test Run, T-02: Test Load  
 T-03: Test Export, T-04: Test Remove  
 T-05: Test Memory

Refer to page 95

- 4 Rotate the Current knob to choose a memory number.
- 5 Press the voltage knob to determine the setting.  
 When the settings are confirmed, "ConF" will be displayed.

Range: 1~10

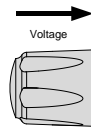

- 6 Press the Test key again to exit the Test settings.  
 The Test key light will turn off.



#### 4.5.4. Load test mode from USB memory

Before loading the test mode data into the internal memory of this product, confirm that there is at least one test mode data file (up to 10 data) in the USB memory.

Before loading the test mode data into the internal memory of this product: Ensure that the test mode data file (paired "tXXX.csv" and "tXXX.tst" files) is located in the root directory of the USB memory.

Ensure that the file name number corresponds to the memory number on this product side.

For example:

A test mode data file named t001 can only be saved to memory number 01 of this product, and a t002 file can only be saved to memory number 02.

steps	Step instructions
-------	-------------------

- |   |  |
|---|--|
| 1 | Verify that the test mode data file is located in the root directory of the USB memory. Insert the USB memory into the front panel USB-A slot. |
|---|--|



- |   |   |
|---|---|
| 2 | When the USB memory is recognized (after a few seconds), "MS (Mass Storage) on" will be displayed at the display. |
|---|---|

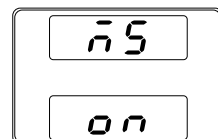



Note

If the USB memory is not recognized, check to see that the function settings for F-20: 1 (page 62).  
If not, reinsert the USB memory.

- 3 Select "T-02" with the Voltage knob, and select the memory number (1 - 10) with the current Knob. Refer to page 95  
After selecting the memory number, press Voltage Knob.



Note

Error messages:  
When selected a file number that does not exist on the USB memory, "Err 002" will appear on the display.



#### 4.5.5. Run Test mode manual operation

The test mode selects and executes one of the 10 test mode data stored in this product's internal memory.

steps	Step instructions	
1	Before running a test mode, save at least one test mode data file to one of the ten memories in this product's internal memory.	Refer to page 97
2	Select "T-01" with the voltage knob, and select the test mode number (1 to 10) in this product's internal memory to be executed with the current knob. Confirm that "y" is displayed at the bottom left of the display.	Refer to page 96
3	Press the voltage knob to begin loading test mode data from the USB memory into this product's internal memory. The internal memory number of this product will be displayed at the top of the display, and "LOAD" will be displayed at the bottom.	



Note

When the test mode data is very small, the loading screen may not appear on the screen for very long.

When press the Test key while loading data, loading will be canceled.

- 4 Once the test mode data has been loaded, the test mode will be in a waiting state.

The internal memory number of this product will be displayed at the top of the display, and "WAIT" will be displayed at the bottom.

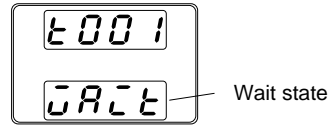

- 5 To run the test mode, press the Output key. The Output key becomes illuminated.

When the mode is running, the measurement results will display as normal. The Test key will flash.

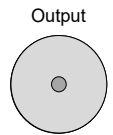

Note

When the test mode is running, press the Output key again to return the test mode to the wait state.

When the test mode is running, press the Test key to abort the execution of the mode and return to normal operating mode. The Test key will led turn off after the test mode has been aborted.



Note

Error messages:

When run a test mode on an internal memory number of this product that has no test mode data loaded, "Err 003" will appear on the display.

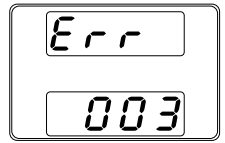

### Automatically at Startup

This product can be configured to automatically run test mode when the power switch is turned on.

steps	Step instructions
-------	-------------------

- |   |   |                                  |
|---|---|----------------------------------|
| 1 | Before running a test mode, save at least one test mode data file to one of the 10 memories in the product's internal memory. | Refer to page <a href="#">97</a> |
| 2 | Turn off power switch of this product.  |                                  |
| 3 | While holding down the Test key, turn on this product's power switch.   | Refer to page <a href="#">76</a> |
| 4 | Rotate the Voltage knob to set the top of the display to "F-92".<br>"F-92": Power-ON Output                                   |                                  |

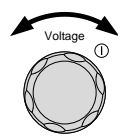

- 5 Rotate the Current knob to select the test mode number that will be run when this product is powered on.

Range: T001~T010

- 6 Press the voltage knob to determine the setting.

The next time turn on the power switch of this product, the selected test mode will be automatically runed.

Press the Test key again to exit the Test settings.

The Test key light will turn off.

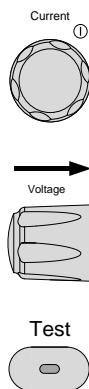

Note

Setting F-92 to 0 or 1 will not run test mode at startup. Refer to the power on configuration settings for details, page 64.

#### 4.5.6. Export Test mode to USB

The test mode export function saves the test mode data as a file in the root directory of the USB memory.

Files will be saved as tXXX.tst where XXX is the memory number 001~010 from which the test mode was exported from.

Files of the same name on the USB memory will be written over.

steps	Step instructions
-------	-------------------

- |   |  |
|---|--|
| 1 | Insert the USB memory into the front panel USB-A slot. |
|---|--|

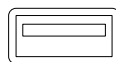

- |   |   |
|---|---|
| 2 | When the USB memory is recognized (after a few seconds), "MS (Mass Storage) on" will be displayed at the display. |
|---|---|

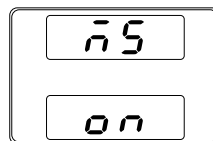

Note

If the USB memory is not recognized, check to see that the function settings for F-20: 1 (page 62). If not, reinsert the USB memory.

- 3 Select "T-03" with the Voltage knob, and select the memory number (1 - 10) with the current Knob.

Refer to page 96

- 4 Press Voltage Knob.

The selected test mode data will be copied to the USB memory.



Note

Error Message:

If there is no test mode data in the selected memory number, "Err 003" will be displayed on the display.

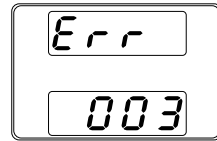

#### 4.5.7. Remove test mode data

The Delete test mode function deletes test mode data from this product internal memory.

steps	Step instructions
1	Select "T-04" with the Voltage knob, and select this product internal memory number (1 – 10, ALL) with the current Knob. <span style="float: right;">Refer to page <a href="#">96</a></span>
2	Press Voltage Knob. The test mode data is deleted from this product internal memory.



Note

Error Message:

If there is no test mode data in the selected this product internal memory number, "Err 003" will be displayed on the display.

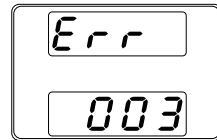

#### 4.5.8. Checking the Available Memory

Displays the amount of remaining memory in this product to load the test mode file. The display unit is kilobytes.

steps	Step instructions
1	Select "T-05" with the Voltage knob. <span style="float: right;">Refer to page <a href="#">96</a></span> The available memory in kilobytes is displayed.

#### 4.5.9. The test mode data file

The test mode data file consists of a pair of CSV format files (tXXX.csv) and TST format files (tXXX.tst). The file name is "tXXX". "XXX" indicates file number 001-010.

CSV format files (tXXX.csv) and TST format files (tXXX.tst) can be downloaded from our website.

The test mode function executes the settings present in the CSV file. Edit the CSV file to create any test mode data. Use the contents of the TST file without changing it.

## Test mode data file structure

In CSV files, items can be omitted if the settings are the same as in the previous line. Please note that step 1 cannot be omitted. If memo is written in the first column, that line will not be executed as a test mode.

The two examples below are test mode data with the same content. Please edit the sections marked in yellow before use.

Step numbers can be increased or decreased (2 – 20000).

### Example data: In excel

	A	B	C	D	E	F	G	H	I	J	K	L	M	N
1	memo	test001												
2	CycleItems	Number	Start Step	End Step										
3	Cycle	2	1	5										
4	DisplayItems	VI												
5	Step	Point	Output	Time(sec)	Voltage (V)	Current (A)	OVP(V)	OCP(A)	Bleeder	IV Mode	Vsr up(V/s)	Vsr down(V/s)	Isr up(A/s)	Isr down(A/s)
6	1	Start	ON	2	10	0.5	MAX	MAX	ON	CVHS	MAX	MAX	MAX	MAX
7	2	ON	ON	2	8	0.8								
8	3	ON	ON	2	6	1								
9	4	ON	ON	2	4	1.2								
10	5	End	OFF	2	1	0.5								

### Example data: In CSV data

memo, test001

CycleItems, Number, Start Step, End Step

Cycle, 2, 1, 5

DisplayItems, VI

Step, Point, Output, Time(sec), Voltage (V), Current (A), OVP(V), OCP(A), Bleeder, IV Mode, Vsr up(V/s), Vsr down(V/s), Isr up(A/s), Isr down(A/s)

1, Start, ON, 2, 10, 0.5, MAX, MAX, ON, CVHS, MAX, MAX, MAX, MAX

2, ON, 2, 8, 0.8

3, ON, 2, 6, 1

4, ON, 2, 4, 1.2

5, End, OFF, 2, 1, 0.5

## Test mode setting items

Item	Unit	Value
Cycle items setting (mandatory): The title name is "Cycle"		
Number: Loop count		0(Infinity), 1 - 100000000
Start Step: Loop start Step		1 - 19999
End Step: Loop end Step		2 - 20000



Note

The test mode runs from the step set to "START" to the step set to "END" in Point.

To make the entire test mode loop, set Start/End Step to the START/END Step set in Point.

To perform a loop operation in the middle of the test mode,



set Start/End Step within the START/END Step set in Point.

Display Items setting: The title name is "DisplayItems"

Displays voltage and current VI

Displays power and current PI

Display voltage and power VP

Setting Values	Unit	Value
----------------	------	-------

Step (mandatory): Script run order		Integer greater than or equal to 1
---------------------------------------	--	------------------------------------

Point

START/END Step (mandatory)

Start and End	START: Start Step, usually "1" END: Last Step
---------------	--

Step between START and END: Condition settings

No conditions	Blank
---------------	-------

Power limit value: P<value>W	P10.05W: 10.05W setting Pmax: Maximum value setting Pmin: Minimum value setting
------------------------------	---



Note

When setting the power limit in the Point section, leave the Step line sections except for "Output" and "Time(sec)" blank.

Logging function start/stop settings	LOG1: Logging function start LOG0: Logging function stop
--------------------------------------	---



Note

When setting the start and end of the logging function in the Point section, leave the Step line sections except for "Output" and "Time(sec)" blank.



Note

The logging function start/stop settings are only available when logging data is output to a USB memory.

## Logging function example

#	A	B	C	D	E	F	G	H	I	J	K	L	M	N
1	memo	PSW_LOG												
2														
3	CycleItems	Number	Start Step	End Step										
4	Cycle	2	2	13										
5														
6	Step	Point	Output	Time(sec)	Voltage (V)	Current (A)	OVP(V)	OCF(A)	Bleeder	IV Mode	Vsr up(V/s)	Vsr down(V/s)	Isr up(A/s)	Isr down(A/s)
7	1	START	ON	1	MIN	1	MAX	MIN	ON	CVHS	MAX	MAX	MAX	MAX
8	2	LOG1	ON		0.1									
9	3		ON			0.1								
10	4		ON			0.2								
11	5		ON			0.3								
12	6		ON			0.4								
13	7		ON			0.5								
14	8		ON			0.6								
15	9		ON			0.7								
16	10		ON			0.8								
17	11		ON			0.9								
18	12		ON			1								
19	13	LOG0	OFF											
20	14	END	OFF			1		0						

### tUVP function setting

UVP0: Function disabled  
 UVP1: Function enabled,  
 instantaneous voltage  
 UVP2: Function enabled,  
 average value voltage



Note

When setting the tUVP function in the Point section, leave the Step line sections except for "Voltage" and "Current" blank.



Note

Set the delay time in the Voltage term and the voltage drop value in the Current term.

### tUVP function example

#	A	B	C	D	E	F	G	H	I	J	K	L	M	N
1	memo	Sequence tUVP Example												
2	memo	UVP Control												
3	memo	[Point] Parameter (UVP) : uvp0, uvp1, uvp2 (F-A0 (0) : uvp0, F-A0 (1) : uvp1, F-A0 (2) : uvp2)												
4	memo	[Voltage] Parameter (UVP Delay) : MIN, MAX, <value>												
5	memo	[Current] Parameter (UVP Level) : MIN, MAX, <value>												
6	DisplayItems	V												
7	CycleItems	Number	Start Step	End Step										
8	Cycle	1	1	11										
9	Step	Point	Output	Time(sec)	Voltage (V)	Current (A)	OVP(V)	OCF(A)	Bleeder	IV Mode	Vsr up(V/s)	Vsr down(V/s)	Isr up(A/s)	Isr down(A/s)
10	1	Start	Off		1	MIN	MAX	MAX	ON	CVHS	MAX	MAX	MAX	MAX
11	2	uvp2				1	0.1							
12	3		On	10	20	5	MAX	MAX	ON	CVHS	MAX	MAX	MAX	MAX
13	4		On	100	19	5	MAX	MAX	ON	CVLS	MAX		0.01	MAX
14	5		On	100	18	5								
15	6		On	100	17	5								
16	7		On	100	16	5								
17	8		On	100	15	5								
18	9		On	100	14	5								
19	10		On	100	13	5								
20	11	End	Off		1	MIN								

Output (mandatory):  
 Step output status

ON: Output on  
 OFF: Output off

Time(sec) (mandatory):  
 Step running time

sec Rang: 0(Skip the run),  
 0.05 -1000000.00  
 Resolution: 0.01



Note

Time(sec): Notes on setting 0  
 There may be a total time lag.  
 It cannot be set for steps where Point is set to "START"  
 and "End".

Voltage (V): Voltage value setting	V	Value or MAX/MIN (See ratings)
Current (A): Current value setting	A	Value or MAX/MIN (See ratings)



Note

When setting the tUVP function, set the delay time in the Voltage section and the voltage drop value in the Current section.

OVP(V): OVP value setting	V	Value or MAX/MIN (See ratings)
OCP(A): OCP value setting	A	Value or MAX/MIN (See ratings)
Bleeder: Bleeder circuit control	ON: Circuit ON OFF: Circuit OFF	
IV Mode: V-I mode slew rate setting	CVHS: CV High speed priority CCHS: CC High speed priority CVLS: CV slew rate priority CCLS: CC slew rate priority	
Vsr up(V/s): Rise voltage slew rate setting	V/s	Value or MAX/MIN (See ratings)
Vsr down(V/s): Fall voltage slew rate setting	V/s	Value or MAX/MIN (See ratings)
Isr up(A/s): Rise current slew rate settings	A/s	Value or MAX/MIN (See ratings)
Isr down(A/s): Fall current slew rate setting	A/s	Value or MAX/MIN (See ratings)



Note

Settings for non mandatory items can be omitted if they are the same as in the previous step.  
Please delete any line blank.  
The number of steps is limited to free memory area, but it is up to step up to 20000.  
The time can be set in 0.01 second increments and the shortest is 0.05 seconds, but please note that setting followability may be limited depending on load conditions and setting values.

## 5. ANALOG CONTROL

The Analog Control chapter describes how to control voltage or current outputs using external voltages or resistors, how to monitor voltage or current outputs, and how to turn off or turn off outputs remotely.

This product has a few analog control options. The Analog Control connectors are used to control output voltage and current using external voltage or resistance. The power supply output and power switch can also be controlled using external contacts.

### 5.1. Analog Control Connector Overview

The Analog Control Connector is a standard Mil 26 pin connector (OMRON XG4 IDC plug). The connector is used for all analog remote control. The pins used determine what remote-control mode is used.



**WARNING** To prevent electric shock, always use the connector cover when the analog control connector is not in use.

Pin Assignment

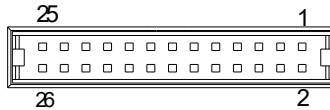

Pin name	No.	Description
Current Share	1	Used when operating 2 or more units in parallel.
D COM	2	This is a COM terminal for OUT ON/OFF CONT (Pin 24) and SHUTDOWN (Pin 12) using external contacts. Electrically connected to the sensing negative pole (-S). It is also connected to the 16-pin A COM.
CURRENT SUM OUT	3	Used during one-control parallel operation. Outputs the output current signal from the slave unit. Calculate the total output current using the master unit.
EXT-V CV CONT	4	Used for external voltage control of voltage output and applies voltage based on A COM (Pin 16). The applied voltage (0 to 10V) sets this product's full-scale voltage output (0% to 100%).

EXT-V CC CONT	5	Used for external voltage control of current output and applies voltage based on A COM (Pin 16). The applied voltage (0 to 10V) sets this product's full-scale current output (0% to 100%).
EXT-R CV CONT PIN1	6	These are terminals for external resistance control of the output voltage. Connect external resistance to pins 6 and 7.
EXT-R CV CONT PIN2	7	The rated output voltage is set from 0% to 100% or from 100% to 0% with an external resistor (0 $\Omega$ to 10k $\Omega$ ).
EXT-R CC CONT PIN1	8	These are terminals for external resistance control of the output current. Connect external resistance to pins 8 and 9.
EXT-R CC CONT PIN2	9	The rated output current is set from 0% to 100% or from 100% to 0% with an external resistor (0 $\Omega$ to 10k $\Omega$ ).
V MON	10	It is this product output voltage monitor. Voltage is output based on A COM (Pin 16). The output voltage (0V to 10V) is proportional to this product's full-scale voltage (0 to 100%).
I MON	11	It is this product output current monitor. Voltage is output based on A COM (Pin 16). The output voltage (0V to 10V) is proportional to this product's full-scale current (0 to 100%).
SHUTDOWN	12	Turn off the output of this product by setting SHUTDOWN to "Low" for D COM (pin 2). (Refer to page <a href="#">117</a> ) The shutdown signal is pulled up to 5V internal to this product with a 10k $\Omega$ pullup resistor.
CURRENT_SUM_1	13	Used during one-control parallel operation. This is the input terminal for the output current signal of the first slave unit. Connect the slave machine 3 pin. Calculate the total output current on the master unit.

CURRENT_SUM_2	14	Used during one-control parallel operation. This is the input terminal for the output current signal of the second slave unit. Connect the slave machine 3 pin. Calculate the total output current on the master unit.
FEEDBACK	15	Used during one-control parallel operation.
A COM	16	These are COM terminals for EXT-V CV CONT (Pin 4), EXT-V CC CONT (Pin 5), V MON (Pin 10), and I MON (Pin 11). Electrically connected to the sensing negative pole (-S) and D COM (Pin 2).
STATUS COM	17	Common terminal for status signals CV (Pin 18), CC (Pin 19), ALM (Pin 20), OUTPUT ON (Pin 21), and POWER OFF (Pin 22). Connected to the emitter of the photocoupler. It is isolated from D COM (Pin 2), A COM (Pin 16) and the case.
CV STATUS	18	This is a photocoupler open collector output. Turns on when this product is in CV mode.
CC STATUS	19	This is a photocoupler open collector output. Turns on when this product is in CC mode.
ALM STATUS	20	This is a photocoupler open collector output. It turns on when this product 's protection function (OVP, OCP) is activated or a shutdown signal is input.
OUTPUT ON STATUS	21	This is a photocoupler open collector output. It is turned on when this product is OUTPUT ON.
POWER OFF STATUS	22	This is a photocoupler open collector output. Turns on when this product is POWER OFF.
N.C.	23	Not connected
OUT ON/OFF CONT	24	Output on control is possible by setting OUT ON/OFF CONT to "High" or "Low" based on D COM (2 pin). (Refer to page 115) The OUT ON/OFF CONT signal is pulled up to 5V inside this product using a 10k $\Omega$ pull-up resistor.
SER SLV IN	25	Series slave input during master-slave series operation.

### 5.1.1. External Voltage Control of Voltage Output

External voltage control of the voltage output uses a MIL-26 connector on the back panel. External voltage (0-10V) is used to control the full-scale voltage of this product.

$$\text{Output voltage} = \text{full scale voltage} \times (\text{external voltage} / 10\text{V})$$

Connection Pin16 → EXT-V (-), Pin4 → EXT-V (+)

When connecting the external voltage source to the MIL connectors, use shielded or twisted paired wiring.

Please use the external voltage in a floating state to prevent this product output from shorting.

Wire shield connection 1:  
-Output terminal

Wire shield connection 2:  
EXT-V ground (GND)

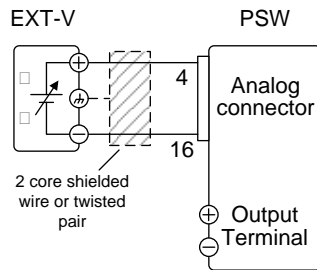
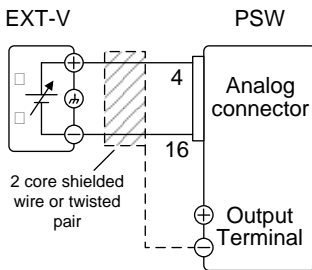

### Panel operation

steps	Step instructions
1	Connect the external voltage according to the connection diagrams above.
2	Set the F-90 power on configuration setting to 1 (Voltage settings: External voltage control). <span style="float: right;">Refer to page <a href="#">76</a></span>
	Be sure to cycle the power after the power on configuration has been set.
3	Press the Function key and confirm the new configuration settings.
	F-90: 1 <span style="float: right;">Function </span>

- 4 Press the Output key.  
The voltage can now be controlled with the External voltage.

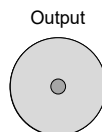

Caution

External voltage control Do not apply a voltage higher than 10.5V to the input terminal. Be sure to wire the external voltage source correctly so as not to mistake the polarity.

The input impedance for external voltage control is 10kΩ.

Use a stable voltage supply for the external voltage control.



Note

When using external voltage control, Output ON/OFF Delay Time (F-01, 02) and V-I mode slew rate select (F-03) are disabled. Refer to Normal Function Settings on page 66.



Caution

Check the isolation voltage specifications of the external voltage before use.

### 5.1.2. External Voltage Control of Current Output

External voltage control of the current output uses a MIL-26 connector on the back panel. External voltage (0-10V) is used to control the full-scale current of this product.

Output current = full scale current × (external voltage / 10V)

Connection Pin16 → EXT-V (-), Pin5 → EXT-V (+)

When connecting the external voltage source to the MIL connectors, use shielded or twisted paired wiring.

Please use the external voltage in a floating state to prevent this product output from shorting.

Wire shield connection 1:  
-output terminal

Wire shield connection 2:  
EXT-V ground (GND)



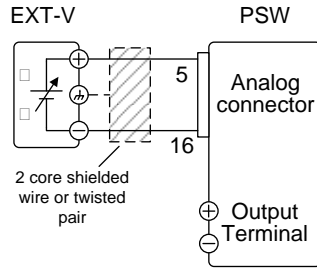
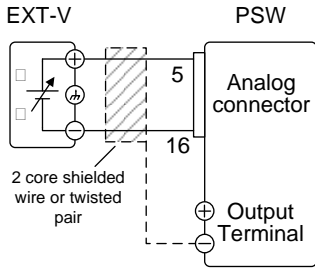

## Panel operation

steps	Step instructions
-------	-------------------

- |   |  |
|---|--|
| 1 | Connect the external voltage according to the connection diagrams above.   |
| 2 | Set the F-91 power on configuration setting to 1 (Current settings: External voltage control). <span style="float: right;">Refer to page <a href="#">76</a></span> |

Be sure to cycle the power after the power on configuration has been set.

- |   |   |
|---|---|
| 3 | Press the Function key and confirm the new configuration settings.<br>F-91: 1 |
|---|---|

Function



- |   |   |
|---|---|
| 4 | Press the Output key.<br>The current can now be controlled with the External voltage. |
|---|---|

Output

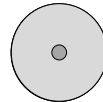

### Caution

External voltage control Do not apply a voltage higher than 10.5V to the input terminal. Be sure to wire the external voltage source correctly so as not to mistake the polarity.

The input impedance for external voltage control is 10kΩ.

Use a stable voltage supply for the external voltage control.



### Note

When using external voltage control, Output ON/OFF Delay Time (F-01, 02) and V-I mode slew rate select (F-03) are disabled. Refer to Normal Function Settings on page [66](#).



Caution

Check the isolation voltage specifications of the external voltage before use.

### 5.1.3. External Resistance Control of Voltage Output

External resistance control of the voltage output is accomplished using the MIL-26 connector on the rear panel. A resistance of 0kΩ~10kΩ is used to control the full-scale voltage of this product.

There are two ways to set the output voltage (0V to rated voltage).

External resistance control 1 (Ext-R  $\swarrow$  10kΩ = V ratings):

Output voltage = full scale voltage × (external resistance / 10kΩ)

External resistance control 2 (Ext-R  $\triangleleft$  10kΩ = 0V):

Output voltage = full scale voltage × (1 – (external resistance / 10kΩ))



Note

For safety reasons, external resistance control 2 is recommended. In the event that the cables become accidentally disconnected, the voltage output will drop to zero. Under similar circumstances using external resistance control 1, an unexpected high voltage would be output.

When switches are used to switch between fixed resistances, use switches that avoid creating open circuits. Use short-circuit or continuous resistance switches.

Connection Pin6 → EXT-R, Pin7 → EXT-R

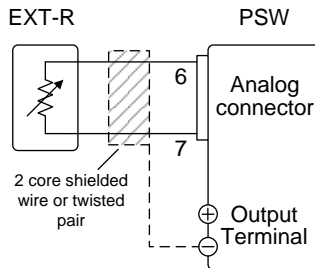

When connecting the external resistance to the MIL connectors, use shielded or twisted paired wiring.

Wire shield connection: -Output terminal



## Panel operation

steps	Step instructions
-------	-------------------

- |   |   |   |
|---|---|---|
| 1 | Connect the external resistance according to the connection diagrams above.   |   |
| 2 | Set the configuration setting when powering on the F-90 to 2 or 3. (Voltage setting: external resistance control 1 or 2)<br>Be sure to cycle the power after the power on configuration has been set. | Refer to page <a href="#">76</a>  |
| 3 | Press the Function key and confirm the new configuration settings.<br>F-90: 2 or 3  |  <p>Function</p> |
| 4 | Press the Output key.<br>The voltage can now be controlled with the External resistance.  |  <p>Output</p>   |



### Caution

Ensure the resistor(s) and cables used exceed the isolation voltage of the power supply. For example: insulation tubes with a withstand voltage higher than the power supply can be used.

When choosing an external resistor ensure the resistor can withstand a high degree of heat.



### Note

When using external resistance control, Output ON/OFF Delay Time (F-01, 02) and V-I mode slew rate select (F-03) are disabled. Refer to Normal Function Settings on page [66](#).

### 5.1.4. External Resistance Control of Current Output

External resistance control of the current output is accomplished using the MIL-26 connector on the rear panel. A resistance of 0kΩ~10kΩ is used to control the full-scale current of this product.

There are two ways to set the output current (0V to rated current).

External resistance control 1 (Ext-R $\searrow$  10kΩ = I ratings):

Output current = full scale current × (external resistance / 10kΩ)

External resistance control 2 (Ext-R $\triangleleft$  10kΩ = 0A):

Output current = full scale current × (1 – (external resistance / 10kΩ))



Note

For safety reasons, external resistance control 2 is recommended. In the event that the cables become accidentally disconnected, the current output will drop to zero. Under similar circumstances using external resistance control 1, an unexpected high current would be output.

When switches are used to switch between fixed resistances, use switches that avoid creating open circuits. Use short-circuit or continuous resistance switches.

Connection Pin8 → EXT-R, Pin9 → EXT-R

When connecting the external resistance to the MIL connectors, use shielded or twisted paired wiring.

Wire shield connection: -Output terminal

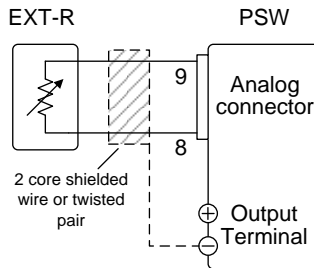

### Panel operation

steps	Step instructions	
1	Connect the external resistance according to the connection diagrams above.	
2	Set the configuration setting when powering on the F-91 to 2 or 3. (Current setting: external resistance control 1 or 2) Be sure to cycle the power after the power on configuration has been set.	Refer to page <a href="#">76</a>
3	Press the Function key and confirm the new configuration settings. F-91: 2 or 3	Function

- 4 Press the Output key.  
The current can now be controlled with the External resistance.

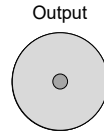

Caution

Ensure the resistor(s) and cables used exceed the isolation voltage of the power supply. For example: insulation tubes with a withstand voltage higher than the power supply can be used.

When choosing an external resistor ensure the resistor can withstand a high degree of heat.



Note

When using external resistance control, Output ON/OFF Delay Time (F-01, 02) and V-I mode slew rate select (F-03) are disabled. Refer to Normal Function Settings on page 66.

#### 5.1.5. External output on

Output on control is possible by setting OUT ON/OFF CONT (24 pin) to "High" or "Low" based on D COM (2 pin).

OUT ON/OFF CONT is pulled up internally to 5V with a 10kΩ pull-up resistor relative to D COM. When OUT ON/OFF CONT and D COM are open, OUT ON/OFF CONT becomes "High". When OUT ON/OFF CONT and D COM are shorted, OUT ON/OFF CONT becomes "Low".

Set "F94" and select whether the output will be turned on at "High" or "Low". (Refer to page 75)

Set F94 to "0": OUT ON/OFF CONT is "High" and output is on.

Set F94 to "1": OUT ON/OFF CONT is "Low" and output is on.

Connection	Switch	Open collector	TTL level signal
Pin24	Switch	Collector	TTL output
Pin2	Switch	Emitter	TTL GND

A TTL level signal can also be input to OUT ON/OFF CONT.

When connecting the external contacts (Switch), etc. to the MIL connectors, use shielded or twisted paired wiring.

Wire shield connection: -Output terminal

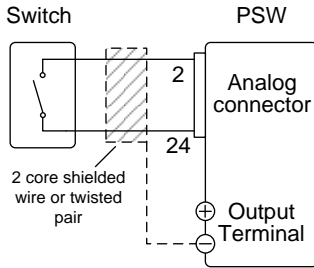

Panel operation

steps	Step instructions	
1	Connect the external resistance according to the connection diagrams above.	
2	Set F-94 (External output logic) in the power on configuration settings to 0 (High = On) or 1 (Low = On). Be sure to cycle the power after the power on configuration has been set.	Refer to page 76
3	Press the Function key and confirm the new configuration settings. F-94: 0 or 1	Function 
The external control is now ready to set the output on or off.		



Note

When using a switch over long distances, please use a switch relay to extend the line from the coil side of the relay.

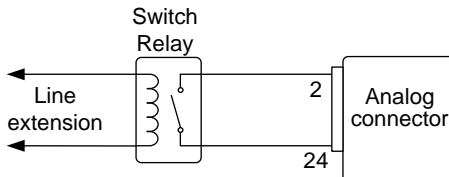

Caution

D COM (pin 2) is electrically connected to the sensing negative electrode. If multiple external contacts are controlled by one external contact, the sensing negative electrode of each device will short-circuit. When controlling with external contacts, basically connect one insulated floating external contact per unit.

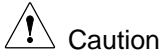

Caution

Ensure the cables used and the switch exceed the isolation voltage of this product. For example: insulation tubes with a withstand voltage higher than this product can be used.



Note

If F-94 = 0 (High = on) and the pin 24 is low (0) "MSG 001" will be displayed on the display.

If F-94 = 1 (Low = on) and the pin 24 is high (1) "MSG 002" will be displayed on the display.

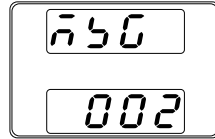
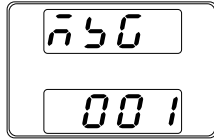

### 5.1.6. Output off by external control

The output status of this product can be turned off using an external switch.

Turn off the output of this product by setting SHUTDOWN (pin 12) to "Low" for D COM (pin 2) as the reference.

SHUTDOWN is pulled up internally to 5V with a 10kΩ pull-up resistor relative to D COM.

Connection	Switch	Open collector	TTL level signal
Pin12	Switch	Collector	TTL output
Pin2	Switch	Emitter	TTL GND

A TTL level signal can also be input to SHUTDOWN.

When connecting the external contacts (Switch), etc. to the MIL connectors, use shielded or twisted paired wiring.

Wire shield connection: -Output terminal

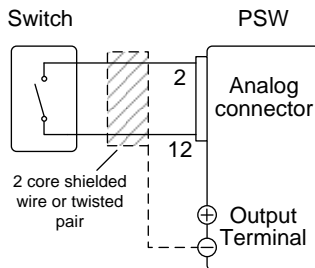



Note

When using a switch over long distances, please use a switch relay to extend the line from the coil side of the relay.

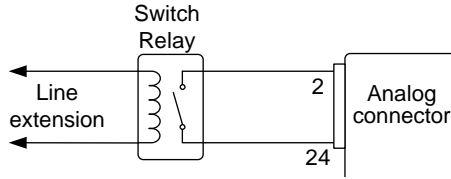

Caution

D COM (pin 2) is electrically connected to the sensing negative electrode. If multiple external contacts are controlled by one external contact, the sensing negative electrode of each device will short-circuit. When controlling with external contacts, basically connect one insulated floating external contact per unit.



Caution

Ensure the cables used and the switch exceed the isolation voltage of this product. For example: insulation tubes with a withstand voltage higher than this product can be used.

## 5.2. Monitor output

This product is equipped with an output current/voltage monitor signal and a status signal that indicates the output status.

### 5.2.1. Output voltage and output current monitor signals

Output voltage monitor signal (V MON) and output current monitor signal (I MON) are output from the MIL-26 connector on the rear panel.

The monitor signal outputs a voltage of 0V to 10V for the 0 to rated output value.

$$VMON = (\text{Output voltage} / \text{full scale voltage}) \times 10V$$

$$IMON = (\text{Output current} / \text{full scale current}) \times 10V$$

Monitor signals do not require configuration settings to be enabled.

Connection



## VMON

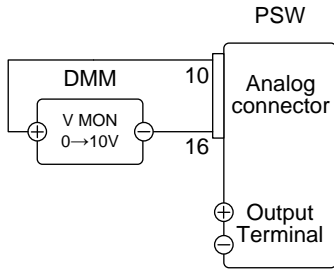

Pin10: DMM (+)  
Pin16: DMM (-)

## IMON

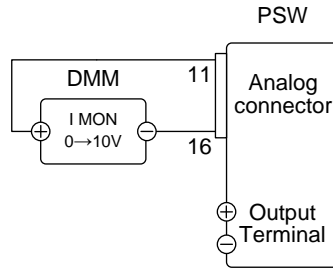

Pin11: DMM (+)  
Pin16: DMM (-)



### Note

VMON and IMON specifications  
Output impedance: 1k $\Omega$ .  
Maximum output current: 10mA.

Each monitor output is a signal output for monitoring the average value of each output. Transient response, ripple & noise, etc. cannot be monitored accurately.



### CAUTION

Do not short VMON and IMON.  
It may cause damage to this product.

## 5.2.2. Operating status signal

Outputs the operating status of this product from the MIL-26 connector on the rear panel.

Each terminal is isolated from the product's internal circuitry by a photocoupler. Status Com (Pin 17) is a photo coupler emitter output, whilst pins 18~22 are photo coupler collector outputs.

Operation specifications of each pin

Maximum applied voltage: 30V, Maximum current: 8mA

It is isolated from D COM (Pin 2), A COM (Pin 16) and the case.

Pin name	No.	Description
STATUS COM	17	Common terminal for CV (Pin 18), CC (Pin 19), ALM (Pin 20), OUTPUT ON (Pin 21), and POWER OFF (Pin 22).
CV STATUS	18	Turns on when this product is in CV mode.
CC STATUS	19	Turns on when this product is in CC mode.

ALM STATUS	20	It turns on when this product's protection function (OVP, OCP) is activated or a shutdown signal is input.
OUTPUT ON STATUS	21	It is turned on when this product is OUTPUT ON.
POWER OFF STATUS	22	Turns on when this product is POWER OFF.

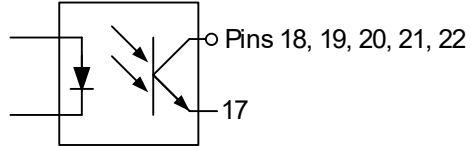

**Timing diagrams** Examples of timing diagrams for various statuses are shown below. Pins 18-22 are active low.

**CV MODE:**  
Output turned on The timing diagram shows when operating in CV mode when the output is on.

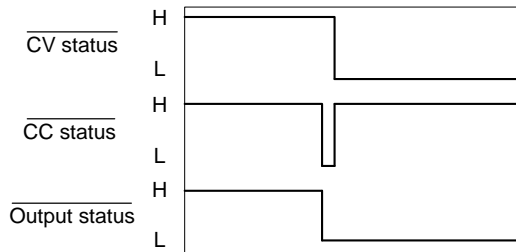

**CV MODE:**  
Output turned off The timing diagram shows the case when the output is turned off while operating in CV mode.

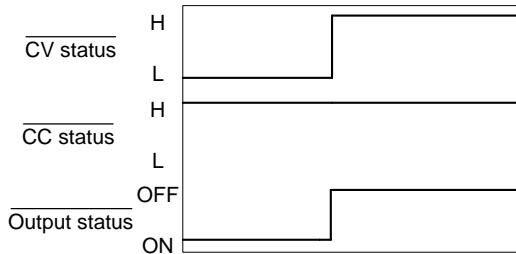

---

CC MODE:  
Output turned on

The timing diagram shows when operating in CC mode when the output is on.

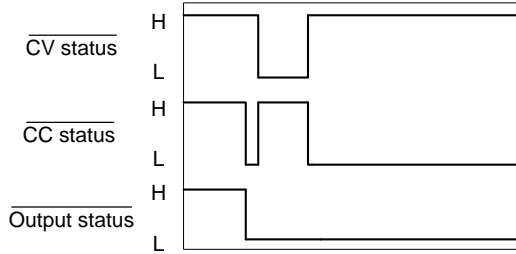

---

CC MODE:  
Output turned off

The timing diagram shows the case when the output is turned off while operating in CC mode.

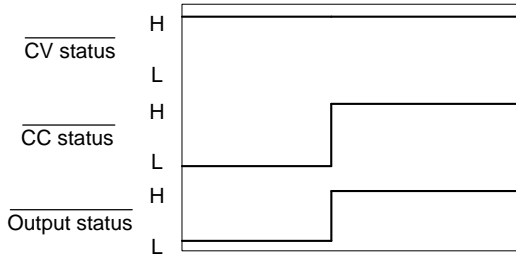

## 6. COMMUNICATION INTERFACE

This chapter describes basic configuration of IEEE488.2 based remote control. For a command list, please refer to the programming manual, which can be downloaded from the TEXIO homepage.

### 6.1. Interface Configuration

#### 6.1.1. Configure USB Remote Interface

USB configuration	PC side connector	Type A, host
	This product side connector	Rear panel Type B, slave
	Speed	1.1/2.0 (full speed/high speed)
	USB Class	CDC (communications device class)

#### Panel operation

steps	Step instructions
-------	-------------------

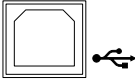
- |   |   |   |
|---|---|---|
| 1 | Connect the USB cable to the rear panel USB B port.   |  |
| 2 | Press the Function key for the Normal configuration settings. Set the rear panel USB port to USB-CDC. F-22: 2 |   |

#### 6.1.2. Configure GP-IB Interface

To use GPIB, the optional GP-IB to USB (GUG-001) adapter must be used. The GPIB to USB adapter must be connected before this product is turned on. Only one GP-IB address can be used at a time.

#### GUG-001 connection and GP-IB settings

steps	Step instructions
-------	-------------------

- |   |   |
|---|---|
| 1 | Ensure this product is power off before proceeding. |
| 2 | Connect the USB cable to the rear panel USB B port. |

- 3 Connect the USB cable type A plug to the USB A port of GUG-001.  
Connect the GP-IB cable from the GP-IB controller to the GP-IB port of GUG-001.

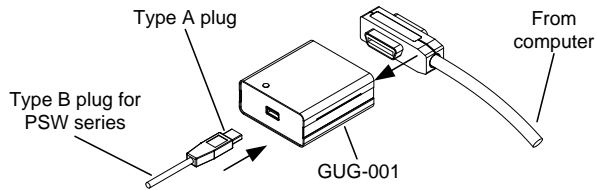

- 4 Turn this product on.
- 5 Press the Function key to enter the Normal configuration settings.

Set the real panel USB port to USB Host. F-22: 1

Set the GP-IB address. F-23: 0~30

**GP-IB constraints** The maximum number of devices connected in one system is 15, including the controller (PC).

The cable length between each device is 2m or less, and the maximum total cable length in one system is 20m or less.

Loop connections and parallel connections of GP-IB cables are prohibited.

Only one address will be assigned to each device; duplication is prohibited. Also, turn on power to 2/3 of all connected devices.

### 6.1.3. Configure RS-232C Interface

RS-232C control is possible by using the optional GUR-001B (RS-232C to USB) adapter.

#### GUR-001B connection and RS-232C settings

- | steps | Step instructions  |
|-------|--|
| 1     | Ensure this product is power off before proceeding.  |
| 2     | Connect the GUR-001B adapter to the USB-B port on the rear panel of this product. Connect to the controller using a cross cable. |

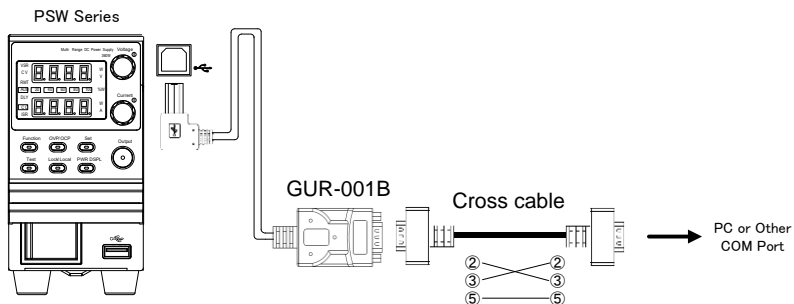

- 3 Turn on the power of this product.
- 4 Press the Function key to make various RS-232C settings.
  - Set the real panel USB port to USB Host. F-22: 1
  - Set the communication baud rate. F-71: 0 - 7
  - Set the data length. F-72: 0 / 1
  - Set the parity. F-73: 0 / 1 / 2
  - Set the stop bit. F-74: 0 / 1

RS-232C constraints Use "LF" as the delimiter.

#### 6.1.4. Configure Ethernet (LAN) Connection

The Ethernet interface can be configured for several different applications. Ethernet can be configured for basic remote control or monitoring using a web server or it can be configured as a socket server.

This product supports both DHCP connections so this product can be automatically connected to an existing network or alternatively, network settings can be manually configured.

##### Ethernet configuration Parameters

MAC Address (display only)	LAN
DHCP	IP Address
Subnet Mask	Gateway
DNS Address	Sockets Active
Web Server Active	Web Password Active
Web set password	0000~9999 (default 0000)
Port number: 2268 (fixed)	

##### Web Server Configuration

This configuration example will configure the PSW as a web server and use DHCP to automatically assign an IP address to the PSW.

**steps Step instructions**

- 1 Connect the Ethernet cable from the network to the Ethernet port on the rear panel.
 

LAN

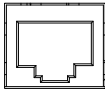
  
- 2 Press the Function key for the Normal configuration settings. Set the following LAN settings:
 

Enable LAN	F-36: 1
Turn DHCP to enable	F-37: 1
Turn the web server on	F-59: 1

 **Note** It may be necessary to cycle the power or refresh the web browser to connect to a network.

**Sockets Server Configuration**

This configuration example will configure the PSW sockets server. The configuration settings instructions will manually assign an IP address to the PSW and enable the socket server. The socket server port number is 2268 (fixed) and cannot be set.

**steps Step instructions**

- 1 Connect the Ethernet cable from the network to the Ethernet port on the rear panel.
 

LAN

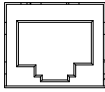
  
- 2 Press the Function key for the Normal configuration settings. Set the following LAN settings:
 

Enable LAN	F-36: 1
Turn DHCP to disable	F-37: 0
IP Address part 1 of 4	F-39: 172
IP Address part 2 of 4	F-40: 16
IP Address part 3 of 4	F-41: 5
IP Address part 4 of 4	F-42: 133
Subnet Mask part 1 of 4	F-43: 255
Subnet Mask part 2 of 4	F-44: 255
Subnet Mask part 3 of 4	F-45: 128
Subnet Mask part 4 of 4	F-46: 0
Gateway part 1 of 4	F-43: 172
Gateway part 2 of 4	F-44: 16
Gateway part 3 of 4	F-45: 21

### 6.1.5. USB Remote Control Function Check

#### Functionality check

Invoke a terminal application such as Realterm. This product will appear as a COM port on the PC.

To check the COM port No, see the Device Manager in the PC.



Note

For more information about sending and receiving remote commands using the Terminal application over a USB connection, refer to page [126](#).

Run this query command via the terminal after this product has been configured for USB remote control.

```
*idn?
```

This will return the manufacturer, model number, serial number, and firmware version.



Note

Please refer to the programming manual for details.

### 6.1.6. Using Realterm to Establish a Remote Connection

Realterm is a terminal program that can be used to communicate with a device attached to the serial port of a PC or via an emulated serial port via USB.

The following instructions apply to version 2.0.0.70. Even though Realterm is used as an example to establish a remote connection, any terminal program can be used that has similar functionality.



Note

Realterm can be downloaded for free on the Internet.

steps	Step instructions
-------	-------------------

- |   |  |
|---|--|
| 1 | Download Realterm and install according to the instructions on the Realterm website. |
| 2 | Connect this product via USB.  |



- 3 Find the COM port number to which this product is connected from Windows Device Manager.

Double click the Ports icon to reveal the connected serial port devices and the COM port for each connected device.

The baud rate, stop bit and parity settings can be viewed for the virtual COM port by right-clicking connected device and selecting the Properties option.

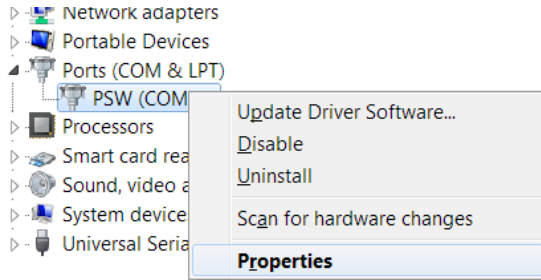

- 4 Start Realterm on the PC as an administrator.  
Tip: to run as an administrator, you can right click the Realterm icon in the Windows Start menu and select the Run as Administrator option.

- 5 After Realterm has started, click on the Port tab.  
Enter settings for the connection's baud rate, parity, data bits, stop bits, and port number.  
The Hardware Flow Control, Software Flow Control options can be left at the default settings.  
Press Open to connect to this product.

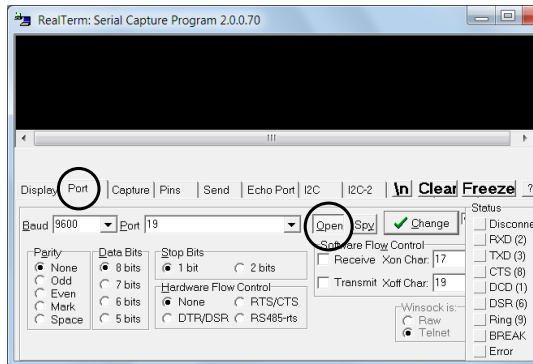

- 6 Click on the Send tab.  
In the EOL configuration, check on the +CR and +LF check boxes.  
Enter the query:  
\*idn?  
Click on Send ASCII.

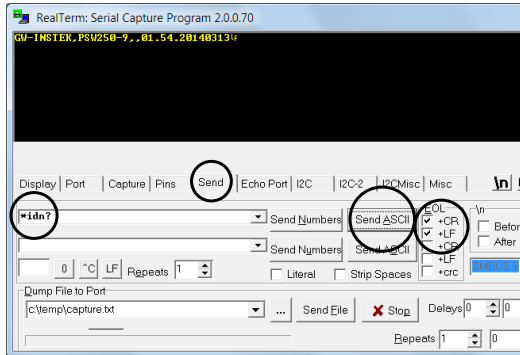

- 7 The terminal display will return the following:  
manufacturer, model, serial number, version
- 8 If Realterm fails to connect to this product, please check all the cables and settings and try again.

### 6.1.7. GP-IB Remote Control Function Check

Its possible use National Instruments Measurement and Automation Explorer (NI MAX) to check if GP-IB connection is working properly. Use of NI MAX requires NI-VISA to be installed.

After installing NI-VISA, download NI-488.2 and complete the installation. NI-488.2 can be downloaded from the NI website [www.ni.com](http://www.ni.com). Find it on the NI website by searching for "NI-488.2 Download."

The following feature checks are based on version 2022 Q3.



Note

NI-VISA can be downloaded from the NI website [www.ni.com](http://www.ni.com). Find it on the NI website by searching for "NI-VISA Download."

#### steps Step instructions

- 1 Complete the setup steps above.

- 2 Start the Measurement and Automation Explorer (MAX) program.  
When using Windows, click in the following order:  
Start > All Programs >  
National Instruments > NI MAX

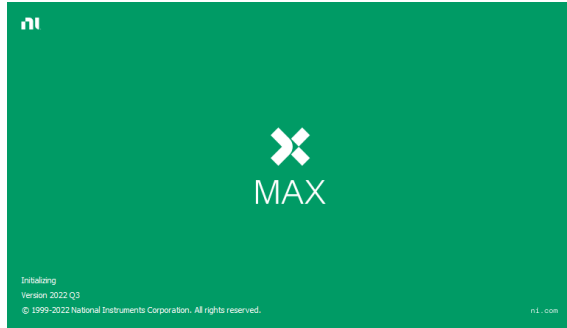

The Measurement & Automation Explorer initial splash screen.

- 3 From the Configuration panel access;  
My System>Devices and Interfaces>GPIB0(GPIB-USB-HS+)
- 4 Press the Scan for Instruments button.

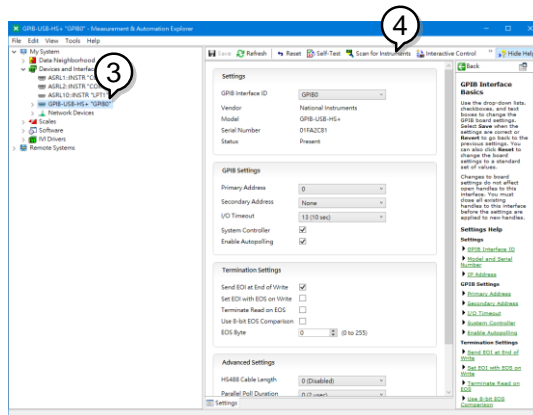

- 5 Click on Communicate with Instrument.
- 6 In the NI-488.2 Communicator window, enter "\*"IDN?" in the Send String text box.  
Click on the Query button to send the \*IDN?
- 7 The String Received text box will display the query return:  
manufacturer, model, serial number, version

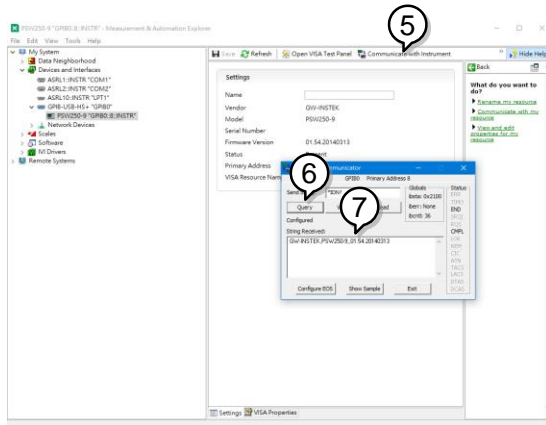

8 The function check is complete.

### 6.1.8. Socket Server Function Check

Its possible use National Instruments Measurement and Automation Explorer (NI MAX) to check if socket server connection is working properly. Use of NI MAX requires NI-VISA to be installed.

The following feature checks are based on version 2022 Q3.



Note

NI-VISA can be downloaded from the NI website [www.ni.com](http://www.ni.com). Find it on the NI website by searching for "NI-VISA Download."

#### steps Step instructions

- 1 Start the NI Measurement and Automation Explorer (MAX) program.

When using Windows, click in the following order:

Start > All Programs >

National Instruments > Measurement & Automation

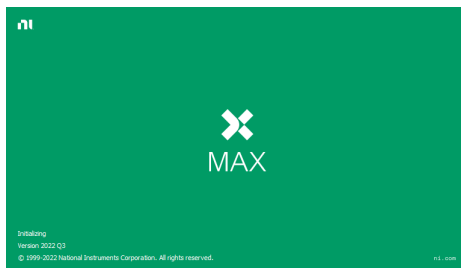

- 2 From the Configuration panel access;  
My System > Devices and Interfaces > Network Devices

- 3 Click Create New... .
- 4 Select VISA TCP/IP Resource.

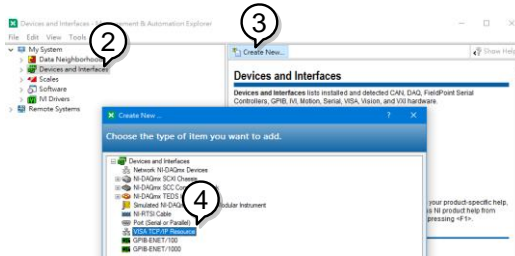

- 5 Select Manual Entry of Raw Socket from the popup window.
- 6 Click Next.

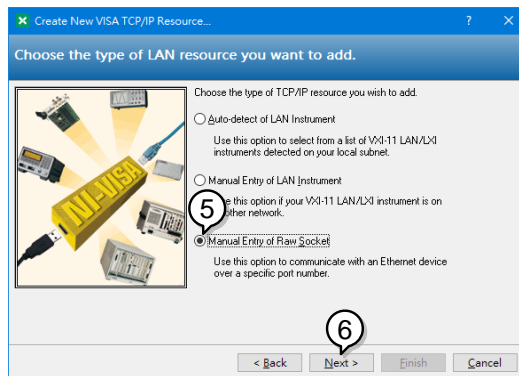

- 7 Enter the IP address and the port number of this product. The port number is fixed at 2268.
- 8 Click the Validate button. A popup box will appear when successful.
- 9 Click Next.

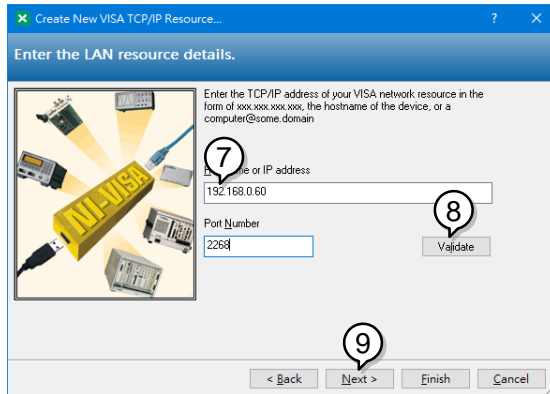

- 10 Next configure the Alias (name) of this product connection. In this example the Alias is: PSW\_DC1
- 11 Click finish.

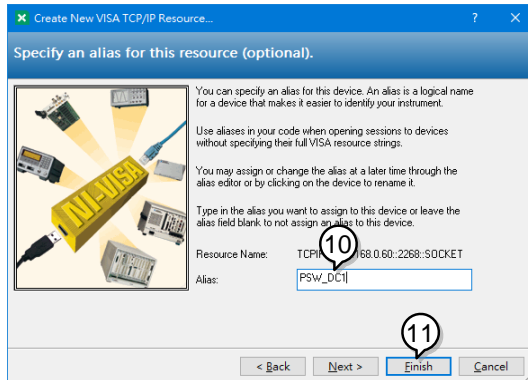

- 12 The IP address of this product will now appear under Network Devices in the configuration panel. Select this icon.
- 13 Press Open VISA Test Panel.

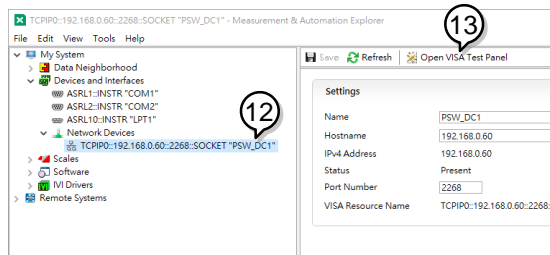

- 14 Click Configuration icon.

- 15 In the I/O Settings tab, select the Enable Termination Character check box. Ensure Line Feed - :\n is selected as the line feed character.
- 16 Click Apply Changes.

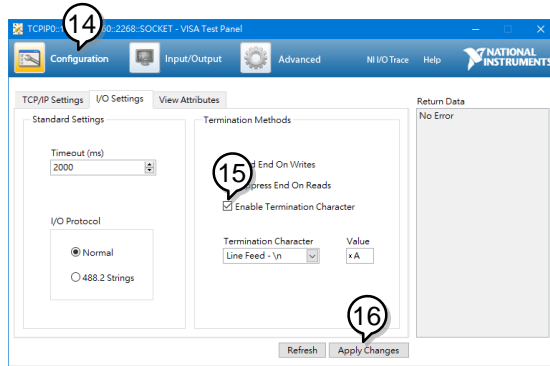

- 17 Click the Input/Output icon.
- 18 Ensure \*IDN? :\n is selected in the Select or Enter Command dropdown text box.
- 19 Click the Query button.
- 20 The \*IDN? query should be returned to the buffer area:

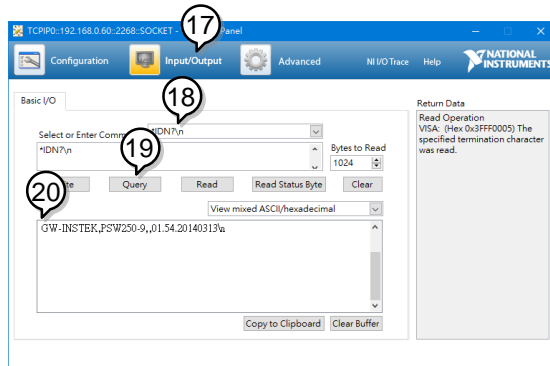

Note

Please refer to the programming manual for more information.

## 7. MAINTENANCE

This product filters should be replaced on a periodic schedule to maintain performance and specification characteristics.

### 7.1. Replacing the Dust Filter

The dust filter should be replaced at least 2 times a year. Not replacing the filter on a regular basis will reduce performance and may cause the unit to overheat.

#### Front Panel Filter Replacement: All Models

- | steps | Step instructions                                       |
|-------|---|
| 1     | Turn this product off.                                  |
| 2     | Pull the filter out from the bottom of the front panel. |

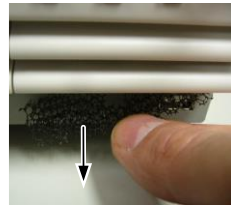

- |   |   |
|---|---|
| 3 | Replace the filter (optional: PSW-010). |
|---|---|

#### Replacing the side panel filter: Type II, III

- | steps | Step instructions                                |
|-------|--|
| 1     | Turn off the product and pull up the side panel. |

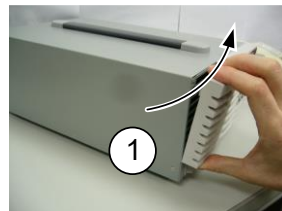

- |   |   |
|---|---|
| 2 | Remove the side panel from the case.  |
| 3 | Remove the filter from the side panel and replace it with a new filter (optional: PSW-010). |

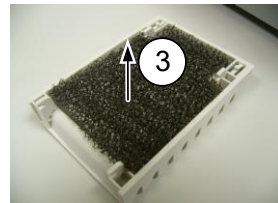



## 8. FAQ

### Question

This product operation mode (CV mode  $\Leftrightarrow$  CC mode) cannot be changed.

### Answer

this product's operating mode (CV and CC) is determined by the set voltage, set current, and load condition connected to this product. Refer to page 19.

### Question

OVP operates at a voltage lower than the OVP setting.

### Answer

When setting OVP, consider the voltage drop from the load line. Since the OVP level is set from the output terminal rather than the load terminal, the voltage at the load terminal may be slightly lower.

### Question

Is it possible to combine cables in parallel for output wiring?

### Answer

Yes. Cables can be used together (in parallel) if the current capacity of a single cable is insufficient. However, the withstand voltage should also be taken into account. Ensure the cables are twisted together and are the same length.

### Question

Accuracy does not meet the specifications.

### Answer

Make sure the ambient temperature is between +20°C and +30°C and the product is powered on for at least 30 minutes. This is a necessary warm-up for the product to meet specifications.

## 9. APPENDIX

### 9.1. Factory default settings

The following settings are this product's factory configuration settings (functional settings/test settings).

For details on how to return to the factory default settings, refer to page [38](#).

Setting items	Initial settings	
Output	Off	
Panel lock	0 (Disabled)	
Voltage setting value	0V	
Current setting value	0A	
OVP setting value	Maximum	
OCP setting value	Maximum	
Normal Function Settings	Setting	Initial settings
Output ON delay time	F-01	0.00s
Output OFF delay time	F-02	0.00s
V-I mode slew rate select	F-03	0 = CV high speed priority
Rising voltage slew rate	F-04	Fastest value for each model
Falling voltage slew rate	F-05	Fastest value for each model
Rising current slew rate	F-06	Fastest value for each model
Falling current slew rate	F-07	Fastest value for each model.
Internal resistance setting	F-08	0.000Ω
Bleeder circuit control	F-09	1: ON
Buzzer ON/OFF control	F-10	1: ON
Measurement Average Setting	F-17	0: Low
Output key operation (In panel lock active)	F-19	0: allow output off
USB/GPIB setting	Setting	Initial settings
Rear Panel USB state	F-22	2: USB CDC
GPIB address	F-23	8
LAN setting	Setting	Initial settings
LAN	F-36	1: Enable
DHCP	F-37	1: Enable
Sockets active	F-57	1: Enable

Web Server active	F-59	1: Enable
Web password active	F-60	1: Enable
Web setting password	F-61	0000
UART setting	Setting	Initial settings
Baud rate	F-71	7: 115200 bps
Data bits	F-72	1: 8 bits
Parity	F-73	0: None
Stop bit	F-74	0: 1 bit
Fan stop function	Setting	Initial settings
Enabling/disabling	F-80	0: Function disabled state
Fan stop time	F-81	1s
Logging function	Setting	Initial settings
Starting/stopping	F-82	0: Stop
Time interval	F-83	1.0s
Storage folder	F-84	0000
Set value digit fixed function	Setting	Initial settings
Voltage set value fixed	F-85	0.1.1.1
Current set value fixed	F-86	0.1.1.1
Power On Configuration	Setting	Default Setting
Voltage settings	F-90	0: Panel control (local)
Current settings	F-91	0: Panel control (local)
Power-ON Output	F-92	0: OFF at startup
External Out Logic	F-94	0: High ON
Power Switch trip	F-95	0: Enable
tUVP function	Setting	Default Setting
Enable/ Disable	F-A0	0: Disable
Delay time	F-A1	1.0s
Voltage drop valu	F-A2	1.00V

## 9.2. Error Messages & Messages

The following error messages or messages may appear on this product's screen during operation.

Error Messages	Description
Err 001	USB Mass Storage is not present

Err 002	No (such)file in USB mass storage
Err 003	Empty memory location
Err 004	File access error
Err 901	Keyboard CPLD error
Err 902	Analog CPLD error
Err 920	The ADC is over range for calibration
Err 921	The DAC is over range for calibration
Err 922	Point invalid for calibration
<b>Messages</b>	<b>Description</b>
MSG 001	External control of output. Output off (F-94: 0, High: on)
MSG 002	External control of output. Output off (F-94: 1, Low: on)
MSG 003	F-93 is not zero. Unable to calibrate.
LOCK F-19	F-19 is zero. Unable to turn the output on.

### 9.3. LED Display Format

Use the following table to read the LED display messages.

0	1	2	3	4	5	6	7	8	9	A	B	C	D
0	1	2	3	4	5	6	7	8	9	A	b	C	d
E	F	G	H	I	J	K	L	M	N	O	P	Q	R
E	F	G	H	I	J	K	L	M	N	O	P	Q	r
S	T	U	V	W	X	Y	Z	(	)	+	-	,	
S	t	U	v	W	X	Y	Z	(	)	+	-	,	_

## 10. Specifications

This specification applies when at least 30 minutes have elapsed after this product was turned on and the ambient temperature is between +18 °C~ +28 °C.

### 10.1. 360W Type I

Model	Unit	PSW-360 L30A	PSW-360 L80A	PSW-360 M160A	PSW-360 M250A	PSW-360 H800A
Rated Output Voltage	V	30	80	160	250	800
Rated Output Current	A	36	13.5	7.2	4.5	1.44
Rated Output Power	W	360	360	360	360	360
Power Ratio		3	3	3.2	3.125	3.2
<b>Constant Voltage Mode</b>						
Line Regulation (*1)	mV	18	43	83	128	403
Load Regulation (*2)	mV	20	45	85	130	405
Ripple and Noise (*3)						
p-p (*4)	mV	60	60	60	80	150
r.m.s (*5)	mV	7	7	12	15	30
Temperature coefficient		100ppm/ °C after a 30-minute warm-up				
Remote sense compensation voltage (single wire)	V	0.6	0.6	0.6	1	1
Rise Time (*6)						
Rated Load	ms	50	50	100	100	150
No Load	ms	50	50	100	100	150
Fall Time (*7)						
Rated Load	ms	50	50	100	150	300
No Load	ms	500	500	1000	1200	2000
Transient response time (*8)	ms	1	1	2	2	2
<b>Constant Current Mode</b>						
Line regulation (*1)	mA	41	18.5	12.2	9.5	6.44
Load regulation (*9)	mA	41	18.5	12.2	9.5	6.44
Ripple and noise						
r.m.s	mA	72	27	15	10	5
Temperature coefficient		200ppm/ °C after a 30-minute warm-up				
<b>Protection Function</b>						
Over voltage protection (OVP)						
Setting range	V	3-33	8-88	16-176	20-275	20-880
Setting accuracy		± (2% of rated output voltage)				
Over current protection (OCP)						
Setting range	A	3.6-39.6	1.35-14.85	0.72-7.92	0.45-4.95	0.144-1.584
Setting accuracy		± (2% of rated output current)				
Under voltage protection (tUVP)						

Setting range	V	0.01-30.00	0.01-80.00	0.1-160	0.1-250	0.1-800
Setting accuracy		± (2% of rated output voltage)				
Over temperature protection (OTP/OHP)		Turn the output off.				
Operation		Turn the output off.				
Low AC input protection (AC-FAIL)		Turn the output off.				
Operation		Turn the output off.				
Power limit (POWER LIMIT)		Over power limit.				
Operation		Over power limit.				
Value (fixed)		Approx. 105% of rated output power				
<b>Analog Programming and Monitoring</b>						
External voltage control output voltage		Accuracy and linearity: ±0.5% of rated output voltage.				
External voltage control output current		Accuracy and linearity: ±1% of rated output current.				
External resistor control output voltage		Accuracy and linearity: ±1.5% of rated output voltage.				
External resistor control output current		Accuracy and linearity: ±1.5% of rated output current.				
Output voltage monitor accuracy	%	±1	±1	±1	±2	±2
Output current monitor accuracy	%	±1	±1	±1	±2	±2
Shutdown control		Turns the output off with a LOW (0V ~ 0.5V) or short-circuit.				
Output on/off control		Possible logic selections: Turn the output on using a LOW (0V ~ 0.5V) or short-circuit, turn the output off using a HIGH (4.5V ~ 5V) or open-circuit. Turn the output on using a HIGH (4.5V ~ 5V) or open-circuit, turn the output off using a LOW (0V ~ 0.5V) or short-circuit.				
CV/CC/ALM/PWR ON/OUT ON indicator		Photocoupler open collector output; Maximum voltage 30V, maximum sink current 8mA.				
<b>Front Panel</b>						
Display		4 digits				
Voltage accuracy 0.1% +	mV	20	20	100	200	400
Current accuracy 0.1% +	mA	40	20	5	5	2
Indications		GREEN LED's: CV, CC, VSR, ISR, DLY, RMT, 20, 40, 60, 80, 100, %W, W, V, A RED LED's: ALM				
Keys		Function, OVP/OCP, Set, Test, Lock/Local, PWR DSPL, Output				
Knobs		Voltage, Current				
USB port		Type A				

## Programming and Measurement (USB, LAN, GPIB)

Output voltage						
programming accuracy						
0.1% +	mV	10	10	100	200	400
Output current						
programming accuracy						
0.1% +	mA	30	10	5	2	2
Output voltage						
programming resolution	mV	1	2	3	5	14
Output current						
programming resolution	mA	1	1	1	1	1
Output voltage						
measurement accuracy						
0.1% +	mV	10	10	100	200	400
Output current						
measurement accuracy						
0.1% +	mA	30	10	5	5	2
Output voltage						
measurement resolution	mV	1	2	3	5	14
Output current						
measurement resolution	mA	1	1	1	1	1

## Series and Parallel Capability

Parallel number	Units	3	3	3	3	3
Series Number	Units	2	2	2	無	無

## Input Characteristics

Nominal input rating	100Vac ~ 240Vac, 50Hz to 60Hz, single phase					
Input voltage range	85Vac ~ 265Vac					
Input frequency	47Hz ~ 63Hz					
Maximum input current						
100Vac	A	5				
200Vac	A	2.5				
Inrush current		<25A peak				
Maximum input power	VA	500				
Power factor (typ)						
100Vac		0.99				
200Vac		0.97				
Efficiency (typ)						
100Vac	%	77	78	79	79	80
200Vac	%	79	80	81	81	82
Hold-up time		20ms or greater				

## General Specifications

Weight (main unit only)		Approx. 3kg
Dimensions (WxHxD)	mm	71×124×350

\*1 At 85 ~ 132Vac or 170 ~ 265Vac, constant load.

\*2 From No-load to Full-load, constant input voltage. Measured at the sensing point in Remote Sense.

\*3 Measure with JEITA RC-9131B (1:1) probe



- \*4 Measurement frequency bandwidth is 10Hz to 20MHz.
- \*5 Measurement frequency bandwidth is 5Hz to 1MHz.
- \*6 From 10% to 90% of rated output voltage, with rated resistive load.
- \*7 From 90% to 10% of rated output voltage, with rated resistive load.
- \*8 Time for output voltage to recover within 0.1% + 10mV of its rated output for a load change from 50 to 100% of its rated output current.
- \*9 For load voltage change, equal to the unit voltage rating, constant input voltage.

## 10.2. 720W Type II

Model	Unit	PSW-720 L30A	PSW-720 L80A	PSW-720 M160A	PSW-720 M250A	PSW-720 H800A
Rated Output Voltage	V	30	80	160	250	800
Rated Output Current	A	72	27	14.4	9	2.88
Rated Output Power	W	720	720	720	720	720
Power Ratio		3	3	3.2	3.125	3.2
<b>Constant Voltage Mode</b>						
Line Regulation (*1)	mV	18	43	83	128	403
Load Regulation (*2)	mV	20	45	85	130	405
Ripple and Noise (*3)						
p-p (*4)	mV	80	80	80	100	200
r.m.s (*5)	mV	11	11	15	15	30
Temperature coefficient		100ppm/ °C after a 30-minute warm-up				
Remote sense compensation voltage (single wire)	V	0.6	0.6	0.6	1	1
Rise Time (*6)						
Rated Load	ms	50	50	100	100	150
No Load	ms	50	50	100	100	150
Fall Time (*7)						
Rated Load	ms	50	50	100	150	300
No Load	ms	500	500	1000	1200	2000
Transient response time (*8)	ms	1	1	2	2	2
<b>Constant Current Mode</b>						
Line regulation (*1)	mA	77	32	19.4	14	7.88
Load regulation (*9)	mA	77	32	19.4	14	7.88
Ripple and noise r.m.s	mA	144	54	30	20	10
Temperature coefficient		200ppm/ °C after a 30-minute warm-up				
<b>Protection Function</b>						
Over voltage protection (OVP)						
Setting range	V	3-33	8-88	16-176	20-275	20-880
Setting accuracy		± (2% of rated output voltage)				
Over current protection (OCP)						
Setting range	A	5-79.2	2.7-29.7	1.44-15.84	0.9-9.9	0.288-3.168

Setting accuracy		± (2% of rated output current)				
Under voltage protection (tUVP)						
Setting range	V	0.01-30.00	0.01-80.00	0.1-160	0.1-250	0.1-800
Setting accuracy		± (2% of rated output voltage)				
Over temperature protection (OTP/OHP)						
Operation		Turn the output off.				
Low AC input protection (AC-FAIL)						
Operation		Turn the output off.				
Power limit (POWER LIMIT)						
Operation		Over power limit.				
Value (fixed)		Approx. 105% of rated output power				
<b>Analog Programming and Monitoring</b>						
External voltage control output voltage		Accuracy and linearity: ±0.5% of rated output voltage.				
External voltage control output current		Accuracy and linearity: ±1% of rated output current.				
External resistor control output voltage		Accuracy and linearity: ±1.5% of rated output voltage.				
External resistor control output current		Accuracy and linearity: ±1.5% of rated output current.				
Output voltage monitor accuracy	%	±1	±1	±1	±2	±2
Output current monitor accuracy	%	±1	±1	±1	±2	±2
Shutdown control		Turns the output off with a LOW (0V ~ 0.5V) or short-circuit.				
Output on/off control		Possible logic selections: Turn the output on using a LOW (0V ~ 0.5V) or short-circuit, turn the output off using a HIGH (4.5V ~ 5V) or open-circuit. Turn the output on using a HIGH (4.5V ~ 5V) or open-circuit, turn the output off using a LOW (0V ~ 0.5V) or short-circuit.				
CV/CC/ALM/PWR ON/OUT ON indicator		Photocoupler open collector output; Maximum voltage 30V, maximum sink current 8mA.				
<b>Front Panel</b>						
Display		4 digits				
Voltage accuracy 0.1% +	mV	20	20	100	200	400
Current accuracy 0.1% +	mA	70	40	30	10	4
Indications		GREEN LED's: CV, CC, VSR, ISR, DLY, RMT, 20, 40, 60, 80, 100, %W, W, V, A RED LED's: ALM				
Keys		Function, OVP/OCV, Set, Test, Lock/Local, PWR DSPL, Output				

Knobs		Voltage, Current				
USB port		Type A				
<b>Programming and Measurement (USB, LAN, GPIB)</b>						
Output voltage programming accuracy						
0.1% +	mV	10	10	100	200	400
Output current programming accuracy						
0.1% +	mA	60	30	15	10	4
Output voltage programming resolution						
	mV	1	2	3	5	14
Output current programming resolution						
	mA	2	2	2	1	1
Output voltage measurement accuracy						
0.1% +	mV	10	10	100	200	400
Output current measurement accuracy						
0.1% +	mA	60	30	15	10	4
Output voltage measurement resolution						
	mV	1	2	3	5	14
Output current measurement resolution						
	mA	2	2	2	1	1
<b>Series and Parallel Capability</b>						
Parallel number	Units	3	3	3	3	3
Series Number	Units	2	2	2	無	無
<b>Input Characteristics</b>						
Nominal input rating		100Vac ~ 240Vac, 50Hz to 60Hz, single phase				
Input voltage range		85Vac ~ 265Vac				
Input frequency		47Hz ~ 63Hz				
Maximum input current						
100Vac	A	10				
200Vac	A	5				
Inrush current		<25A peak				
Maximum input power	VA	500				
Power factor (typ)						
100Vac		0.99				
200Vac		0.97				
Power factor (typ)						
100Vac	%	77	78	79	79	80
200Vac	%	79	80	81	81	82
Hold-up time		20ms or greater				
<b>General Specifications</b>						
Weight (main unit only)		Approx. 5.3kg				
Dimensions (WxHxD)	mm	142x124x350				

\*1 At 85 ~ 132Vac or 170 ~ 265Vac, constant load.

- \*2 From No-load to Full-load, constant input voltage. Measured at the sensing point in Remote Sense.
- \*3 Measure with JEITA RC-9131B (1:1) probe
- \*4 Measurement frequency bandwidth is 10Hz to 20MHz.
- \*5 Measurement frequency bandwidth is 5Hz to 1MHz.
- \*6 From 10% to 90% of rated output voltage, with rated resistive load.
- \*7 From 90% to 10% of rated output voltage, with rated resistive load.
- \*8 Time for output voltage to recover within 0.1% + 10mV of its rated output for a load change from 50 to 100% of its rated output current.
- \*9 For load voltage change, equal to the unit voltage rating, constant input voltage.

### 10.3. 1080W Type III

Model	Unit	PSW-1080 L30A	PSW-1080 L80A	PSW-1080 M160A	PSW-1080 M250A	PSW-1080 H800A
Rated Output Voltage	V	30	80	160	250	800
Rated Output Current	A	108	40.5	21.6	13.5	4.32
Rated Output Power	W	1080	1080	1080	1080	1080
Power Ratio		3	3	3.2	3.125	3.2
<b>Constant Voltage Mode</b>						
Line Regulation (*1)	mV	18	43	83	128	403
Load Regulation (*2)	mV	20	45	85	130	405
Ripple and Noise (*3)						
p-p (*4)	mV	100	100	100	120	200
r.m.s (*5)	mV	14	14	20	15	30
Temperature coefficient		100ppm/ °C after a 30-minute warm-up				
Remote sense compensation voltage (single wire)	V	0.6	0.6	0.6	1	1
Rise Time (*6)						
Rated Load	ms	50	50	100	100	150
No Load	ms	50	50	100	100	150
Fall Time (*7)						
Rated Load	ms	50	50	100	150	300
No Load	ms	500	500	1000	1200	2000
Transient response time (*8)	ms		1	1	2	2
<b>Constant Current Mode</b>						
Line regulation (*1)	mA	113	45.5	26.6	18.5	9.32
Load regulation (*9)	mA	113	45.5	26.6	18.5	9.32
Ripple and noise						
r.m.s	mA	216	81	45	30	15
Temperature coefficient		200ppm/ °C after a 30-minute warm-up				
<b>Protection Function</b>						
Over voltage protection (OVP)						
Setting range	V	3-33	8-88	16-176	20-275	20-880

Setting accuracy		± (2% of rated output voltage)				
Over current protection (OCP)						
Setting range	A	5-118.8	4.05-44.55	2.16-23.76	1.35-14.85	0.432-4.752
Setting accuracy		± (2% of rated output current)				
Under voltage protection (tUVP)						
Setting range	V	0.01-30.00	0.01-80.00	0.1-160	0.1-250	0.1-800
Setting accuracy		± (2% of rated output voltage)				
Over temperature protection (OTP/OHP)						
Operation		Turn the output off.				
Low AC input protection (AC-FAIL)						
Operation		Turn the output off.				
Power limit (POWER LIMIT)						
Operation		Over power limit.				
Value (fixed)		Approx. 105% of rated output power				
<b>Analog Programming and Monitoring</b>						
External voltage control output voltage		Accuracy and linearity: ±0.5% of rated output voltage.				
External voltage control output current		Accuracy and linearity: ±1% of rated output current.				
External resistor control output voltage		Accuracy and linearity: ±1.5% of rated output voltage.				
External resistor control output current		Accuracy and linearity: ±1.5% of rated output current.				
Output voltage monitor accuracy	%	±1	±1	±1	±2	±2
Output current monitor accuracy	%	±1	±1	±1	±2	±2
Shutdown control		Turns the output off with a LOW (0V ~ 0.5V) or short-circuit.				
Output on/off control		Possible logic selections: Turn the output on using a LOW (0V ~ 0.5V) or short-circuit, turn the output off using a HIGH (4.5V ~ 5V) or open-circuit. Turn the output on using a HIGH (4.5V ~ 5V) or open-circuit, turn the output off using a LOW (0V ~ 0.5V) or short-circuit.				
CV/CC/ALM/PWR ON/OUT ON indicator		Photocoupler open collector output; Maximum voltage 30V, maximum sink current 8mA.				
<b>Front Panel</b>						
Display		4 digits				
Voltage accuracy 0.1% +	mV	20	20	100	200	400
Current accuracy 0.1% +	mA	100	50	30	20	6

Indications	GREEN LED's: CV, CC, VSR, ISR, DLY, RMT, 20, 40, 60, 80, 100, %W, W, V, A RED LED's: ALM					
Keys	Function, OVP/OCP, Set, Test, Lock/Local, PWR DSPL, Output Voltage, Current					
Knobs	Voltage, Current					
USB port	Type A					
Programming and Measurement (USB, LAN, GPIB)						
Output voltage programming accuracy						
0.1% +	mV	10	10	100	200	400
Output current programming accuracy						
0.1% +	mA	100	40	20	15	6
Output voltage programming resolution						
mV		1	2	3	5	14
Output current programming resolution						
mA		3	3	3	1	1
Output voltage measurement accuracy						
0.1% +	mV	10	10	100	200	400
Output current measurement accuracy						
0.1% +	mA	100	40	20	15	6
Output voltage measurement resolution						
mV		1	2	3	5	14
Output current measurement resolution						
mA		3	3	3	1	1
Series and Parallel Capability						
Parallel number	Units	3	3	3	3	3
Series Number	Units	2	2	2	無	無
Input Characteristics						
Nominal input rating	100Vac ~ 240Vac, 50Hz to 60Hz, single phase					
Input voltage range	85Vac ~ 265Vac					
Input frequency	47Hz ~ 63Hz					
Maximum input current						
100Vac	A	15				
200Vac	A	7.5				
Inrush current	<75A peak					
Maximum input power	VA	1500				
Power factor (typ)						
100Vac		0.99				
200Vac		0.97				
Efficiency (typ)						
100Vac	%	77	78	79	79	80
200Vac	%	79	80	81	81	82
Hold-up time	20ms or greater					

## General Specifications

Weight (main unit only)	Approx. 7.5kg
Dimensions (WxHxD) mm	214x124x350
*1	At 85 ~ 132Vac or 170 ~ 265Vac, constant load.
*2	From No-load to Full-load, constant input voltage. Measured at the sensing point in Remote Sense.
*3	Measure with JEITA RC-9131B (1:1) probe
*4	Measurement frequency bandwidth is 10Hz to 20MHz.
*5	Measurement frequency bandwidth is 5Hz to 1MHz.
*6	From 10% to 90% of rated output voltage, with rated resistive load.
*7	From 90% to 10% of rated output voltage, with rated resistive load.
*8	Time for output voltage to recover within 0.1% + 10mV of its rated output for a load change from 50 to 100% of its rated output current.
*9	For load voltage change, equal to the unit voltage rating, constant input voltage.

## 10.4. Common

### Interface Capabilities

USB	TypeA: Host, TypeB: Slave, Speed: 1.1/2.0, USB Class: CDC(Communications Device Class)
LAN	MAC Address, DNS IP Address, User Password, Gateway IP Address, Instrument IP Address, Subnet Mask
GP-IB	Optional: GUG-001(GP-IB - USB Adapter)
RS-232C	Optional: GUR-001B(RS-232C - USB Adapte)

### Environmental Conditions

Operating temperature	0°C ~ 50°C
Storage temperature	-25°C ~ 70°C
Operating humidity	20% ~ 85% RH; No condensation
Storage humidity	90% RH or less; No condensation
Altitude	Maximum 2000m, Indoor use, Overvoltage category II

### General Specifications

Cooling	Forced air cooling by internal fan.
EMC	EN61326-1 (CLASS A) 2014/30/EU
LVD	EN61010-1 (Class 1, Pollution Degree 2) 2014/35/EU
Withstand voltage	Between input and chassis: No abnormalities at 1500 Vac for 1 minute. Between input and output: No abnormalities at 3000 Vac for 1 minute. Between output and chassis: No abnormalities at 500 Vdc for 1 minute for 30V, 80V, 160V models. No abnormalities at 1500 Vdc for 1 minute for 250V, 800V models

Insulation resistance

Between input and chassis: 500 Vdc, 100M $\Omega$  or more

Between input and output: 500 Vdc, 100M $\Omega$  or more

Between output and chassis :

500 Vdc, 100M $\Omega$  or more for 30V, 80V, 160V and 250V models.

1000Vdc, 100M $\Omega$  or more for 800V models.



# 11. PSW-A Dimensions

## 11.1. 360W Type I

PSW-360L30A / PSW-360L80A / PSW-360M160A (scale: mm)

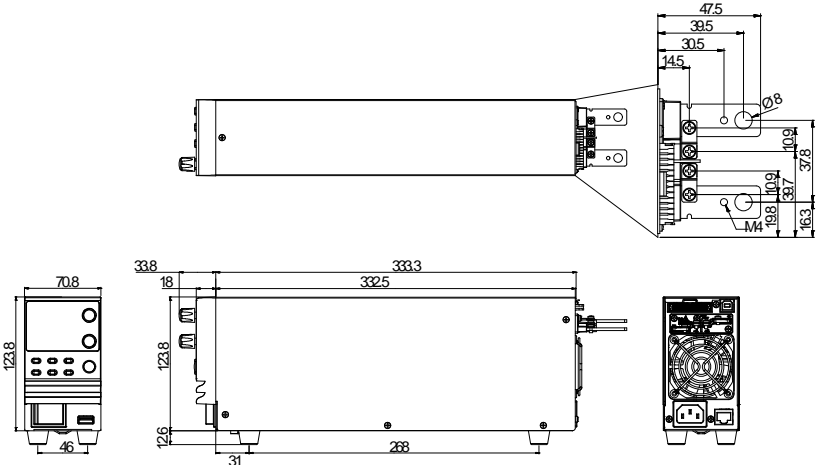

PSW-360M250A / PSW-360H800A (scale: mm)

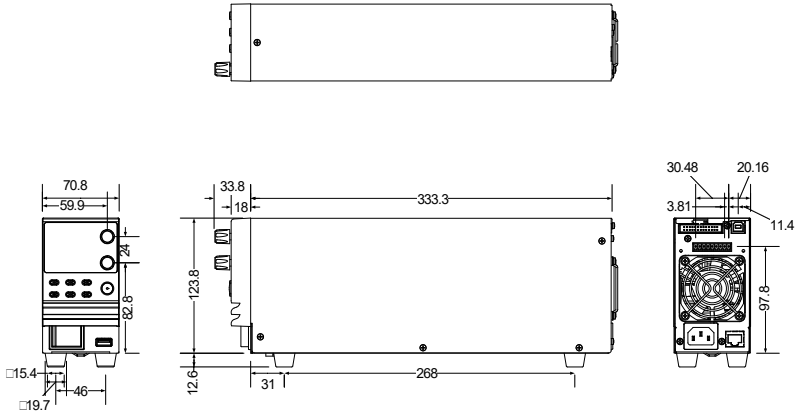

# 11.2. 720W Type II

PSW-720L30A / PSW-720L80A / PSW-720M160A (scale: mm)

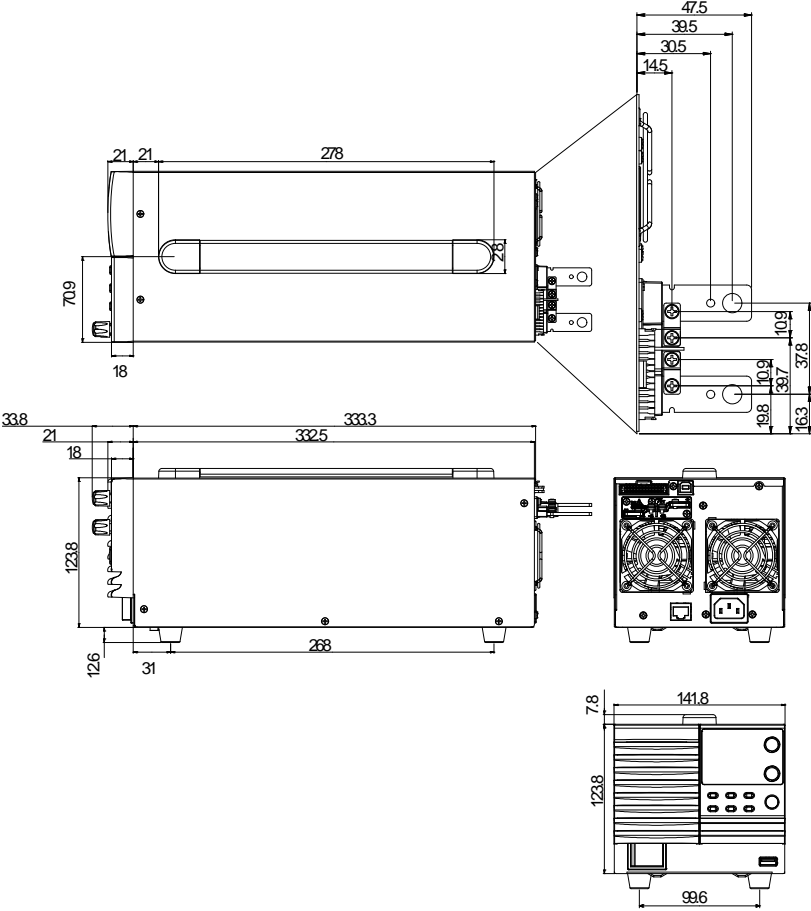

PSW-720M250A / PSW-720H800A (scale: mm)

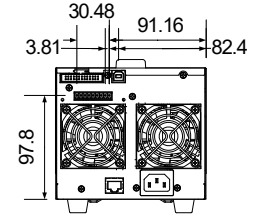
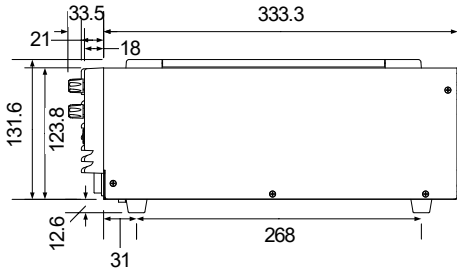
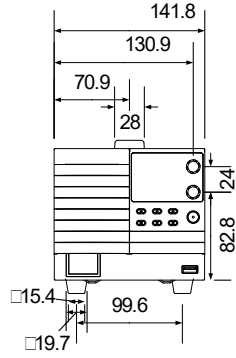
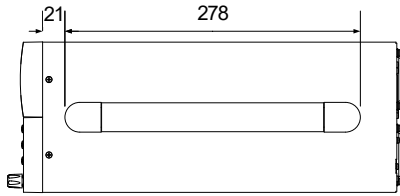

### 11.3. 1080W Type III

PSW-1080L30A / PSW-1080L80A / PSW-1080M160A (scale: mm)

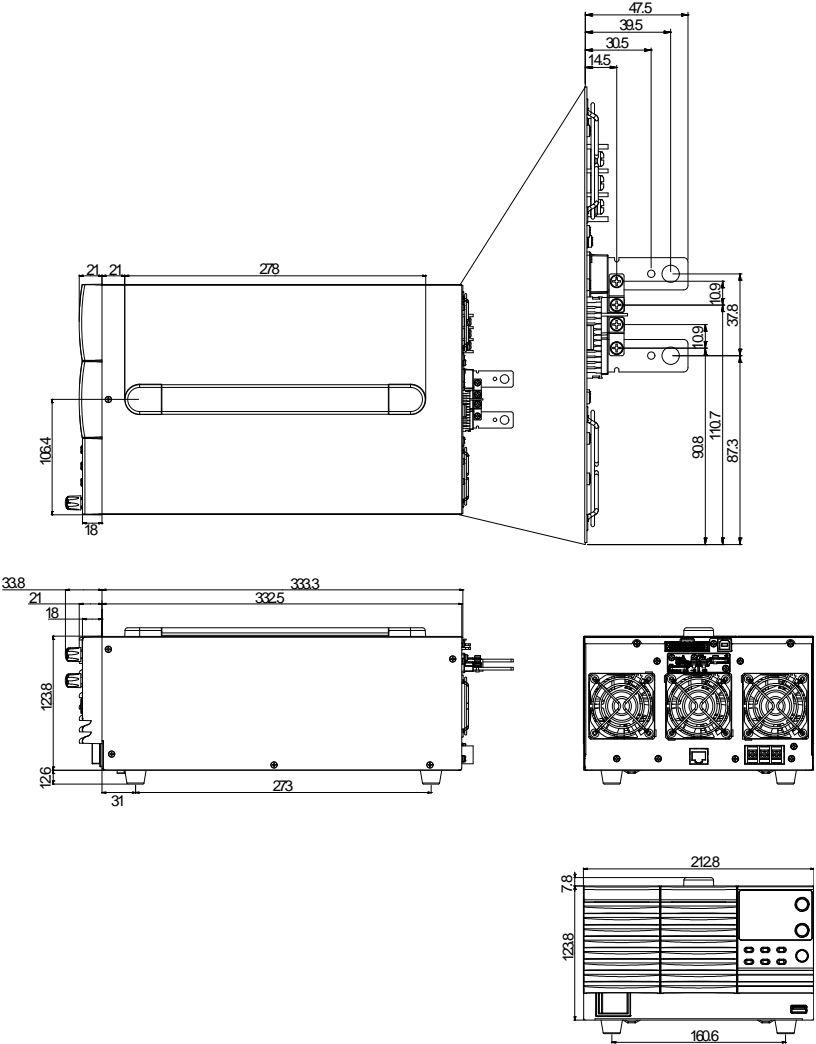





**TEXIO TECHNOLOGY CORPORATION**

7F Towa Fudosan Shin Yokohama Bldg.  
2-18-13, Shin Yokohama, Kohoku-ku, Yokohama, Kanagawa, 222-0033 Japan  
<http://www.texio.co.jp/>

